

20

CLUTCH

Page

Identification20-1
Exploded view20-1
Description20-2
Products20-2
Tightening Torques20-3
Mechanism20-4
Stop20-5
Housing20-6

21

GEARBOX

Characteristics21-1
Gear ratio diagrams21-2
Lubricants21-4
Products21-5
Special tools21-6
Tightening Torques21-7
Gearbox rebuilds21-10
Barrel potentiometer21-27
Engine shutdown switch21-28

22

GEAR MECHANISM

Control cable22-1
Release cable22-3
Gearshift lever22-4

CLUTCH Identification

20

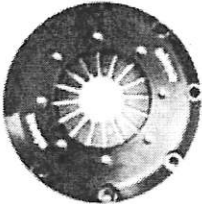
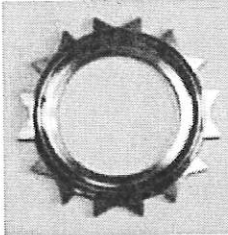
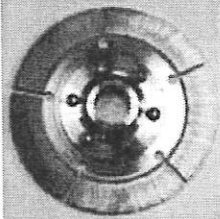
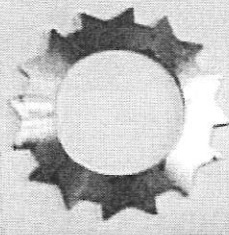
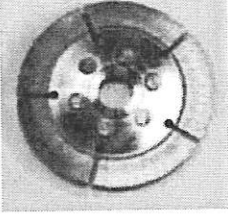
				
<p>Mechanism Type : ALCON</p>	<p>Thrust plate</p>	<p>Friction disc 1 Diameter : 5"1/2 Splines : 23 Pressure angle: 30° Material : Cerometallic</p>	<p>Intermediaries Thrust plate</p>	<p>Friction disc 2 Diameter : 5"1/2 Splines : 23 Pressure angle: 30° Material : Cerometallic</p>

Exploded view

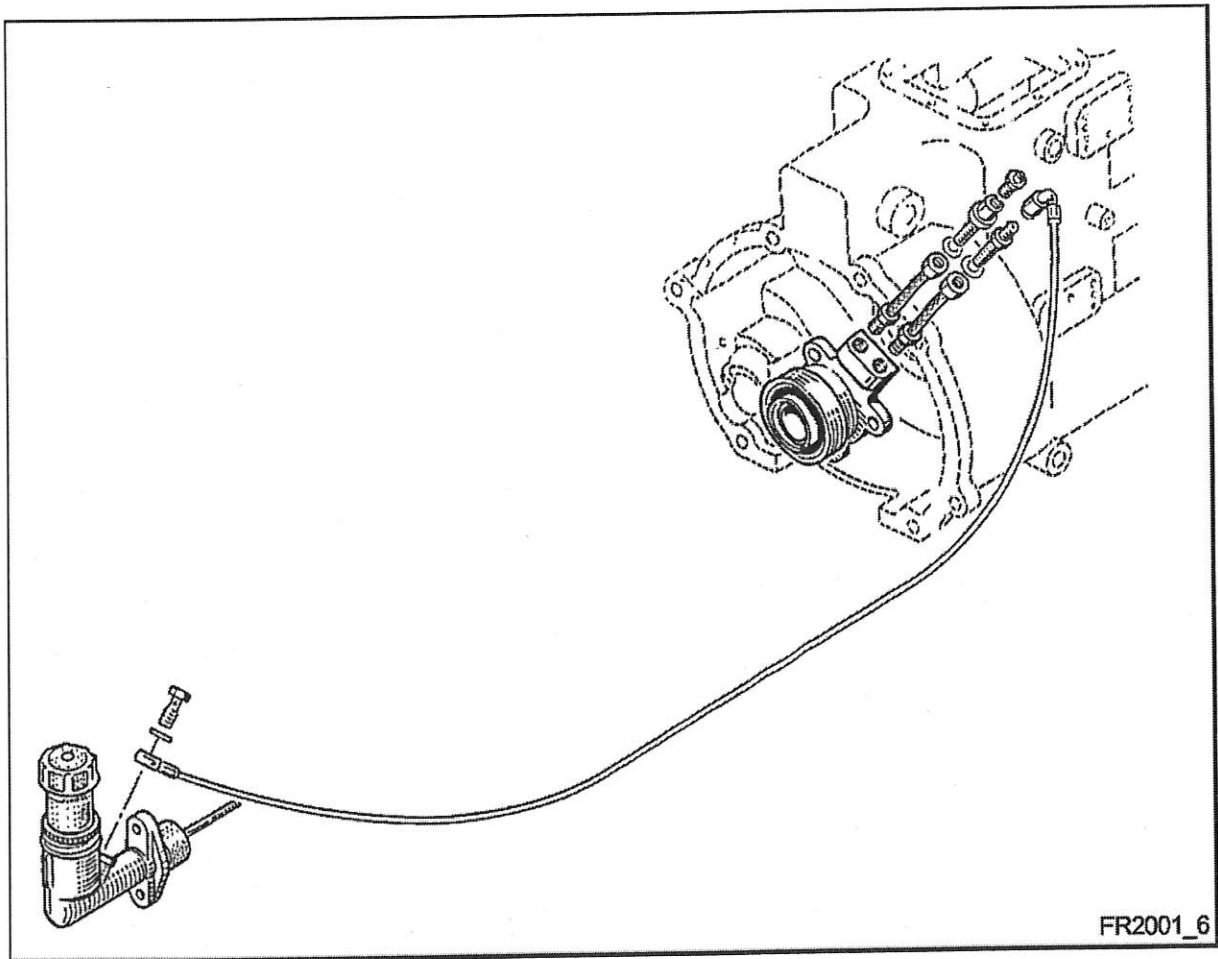

FR2001_6

CLUTCH Identification

20

The clutch is dual-disc with hydraulic control (1), runs dry. It is installed on the front of the engine oil housing forming the clutch housing. It contains:

- a diaphragm clutch plate,
- hydraulic ball bearing (2) in constant abutment,
- 7/10° master cylinder.

NOTA: Overhaul of the master cylinder requires use of Renault repair kit P/N: 77 11 150 528.

NOTA: It is permitted to install a fast coupler on the clutch hydraulic circuit.

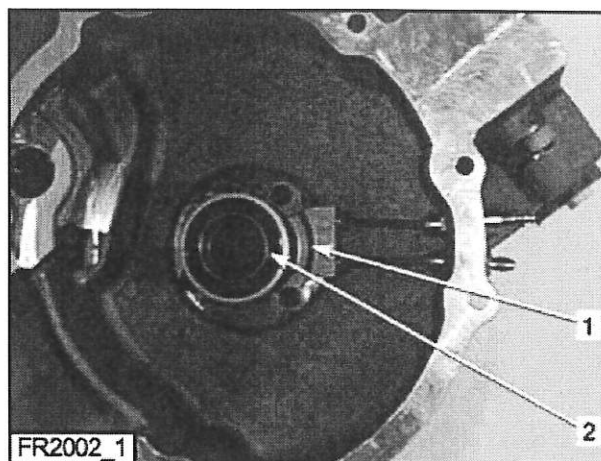

Products

TYPE	ORGANE
Copper grease	Clutch or gearbox output shaft.
DOT 5 hydraulic fluid	Clutch system
LOCTITE 222 low-strength Thread locker	Housing mounting bolt
LOCTITE 243 medium-strength Thread locker	Hydraulic bearing mounting bolt
LOCTITE 518 sealing compound	Box/housing mating plane

CLUTCH

Tightening torques

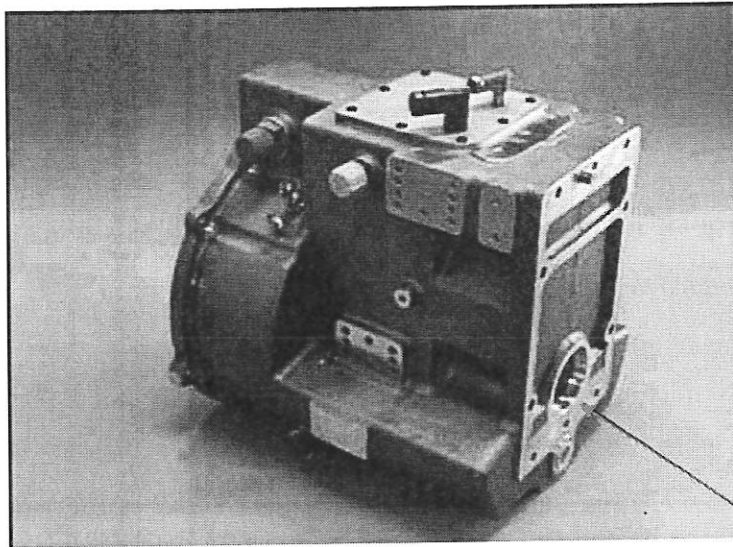

Gearbox/housing
mating plane:
LOCTITE 518
sealing compound

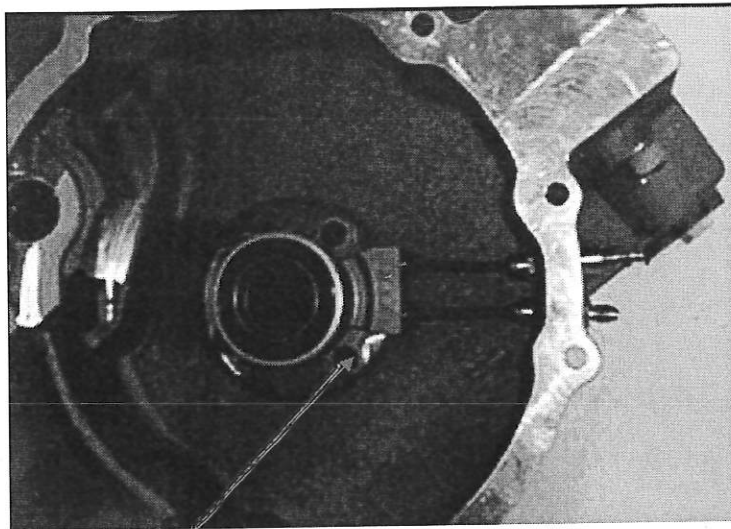

Hydraulic bearing bolt: 22N.m
LOCTITE 243 medium-strength thread

REPLACEMENT

Special tools required: OUT 008 5002 Centring tool
Tightening torque: mechanism screw 22,5N.m

Removal

- Remove the gearbox.
- Install centring tool OUT 008 5002 (to prevent friction disc from falling).
- Remove attaching screws from mechanism (1).
- Remove mechanism, thrust plates (2) and friction devices (3). Mark order and direction of installation.
- Remove attaching screws from mechanism (1).

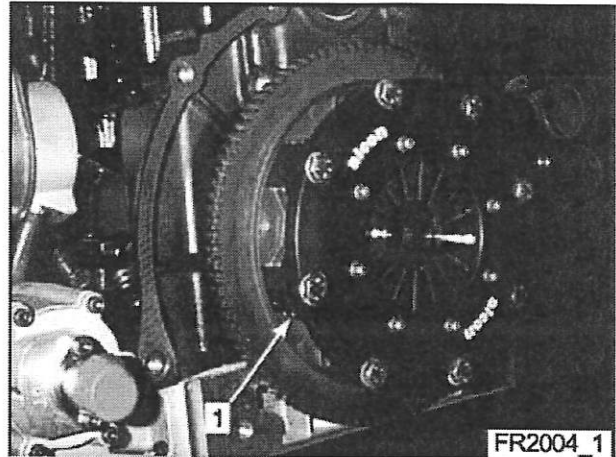

Installation

- Degrease flywheel-attaching face.
- Slightly smear clutch shaft splines with copper grease.
- Install thrust plates and friction devices in the order marked on removal.

NOTA: Observe direction of installation of discs: shift largest hub turned towards clutch mechanism.

- Install clutch mechanism and secure using screws (1).
- Progressively tighten in a star pattern then apply the prescribed torque.
- Remove both centring tool and retaining quadrant.
- Install the gearbox.

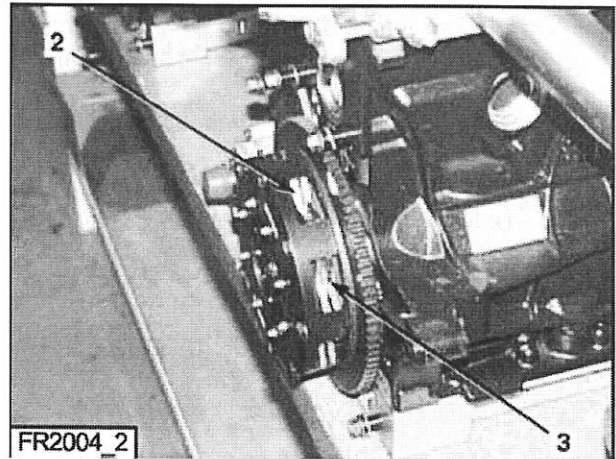

REPLACEMENT

Removal

- Remove the gearbox.
- Drain hydraulic lines.
- Remove connector (1), bulkhead union (2) and the two pipes (3).
- Remove the three bolts (4) fastening the clutch stop. Remove stop.

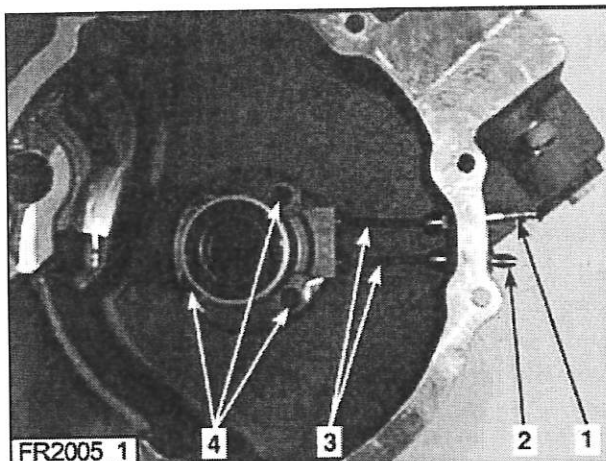

Installation

- Clean with an M7x100 tap, and then remove grease from bolts and tapings.
- Slightly tighten pipes onto clutch stop.

NOTA: Lubricate end fittings on pipes with hydraulic stop oil to seal them.

- Take threads on connector (1) and bulkhead union (2) up onto the two pipes (3) then position stop.
- Put a few drops of LOCTITE 243 medium-strength Thread locker on bolts. Fasten clutch stop onto housing. Torque bolts to 22N.m.
- Slightly tighten connector and bulkhead union. Bleed hydraulic system for connector plug (1).

NOTA: When tightening bleed plug, correctly secure connector with an open-end wrench. Risk of damaging system sealing.

- Check sealing of assembly.

REPAIR

Housing crankcase near the starter.

In case of crack of the clutch housing near the starter, according to the drawing, it is authorized to repair by a welding cord on each parts of the housing with a maximum length of 3,5cm (1,378in) without any additional part.

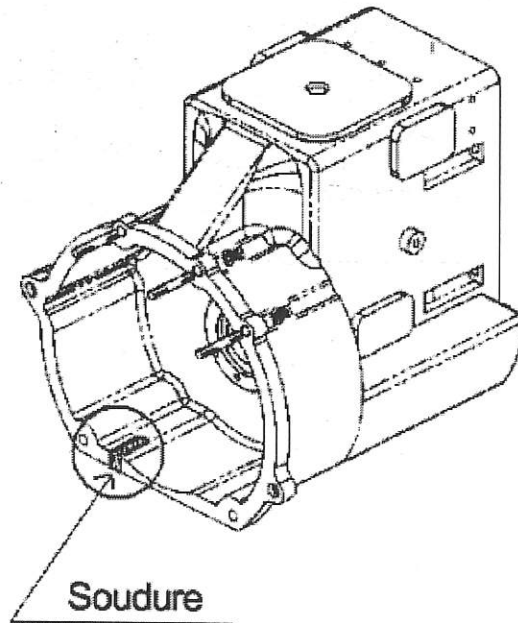

PRESENTATION

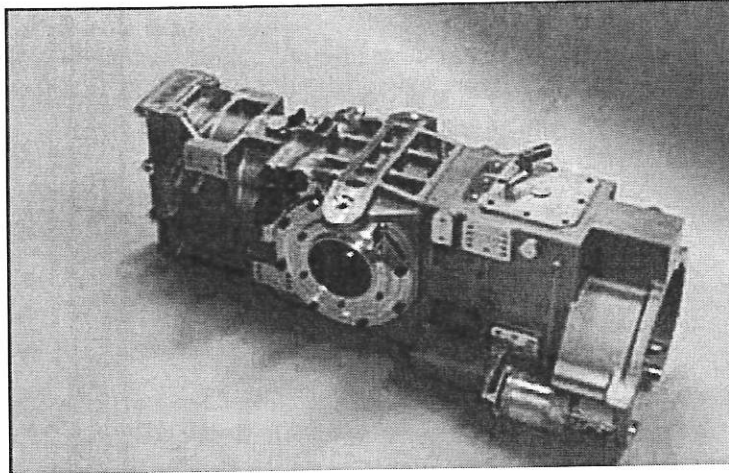

The Renault Sport gearbox is a SADEV SL75/14 FR 2.0, type it has 6 forward gears and one reverse which can quickly be changed.

The gearbox control is sequential.

The gearbox is fitted with a ZF limited slip differential; the tripod transmission seals are integrated inside the differential. The rev limiter switch is integrated in the gearbox.

Weight of gearbox assembly without oil casing: 45kg.

TECHNICAL DATA ON GEARS

Three ratio sets, which cannot be combined, are available, depending on the circuit characteristics.

Short staging ratios

Bevel	1 st	2 nd	3 rd	4 th	5 th	6 th
10	12	16	16	18	21	23
31	36	36	29	27	27	26

Medium staging ratios

Bevel	1 st	2 nd	3 rd	4 th	5 th	6 th
10	12	17	19	20	20	22
31	34	36	32	28	24	23

Long staging ratios

Bevel	1 st	2 nd	3 rd	4 th	5 th	6 th
10	14	18	18	21	20	27
31	37	35	28	27	22	26

Reverse ratio

The reverse ratio is constant.

14	
18	Transfer
40	

5th gear in the short version (21 / 27) is equal as 4th in the long version (21 / 27). The engraving "SHORT" or "LONG" will identify these.

It is essential to fit the gears marked "SHORT" in short staging, and those marked "LONG" in long staging.

LIMITED SLIP DIFFERENTIAL

The LSD acts symmetrically on acceleration and deceleration.

The slopes used on the plates give a friction percentage of 45%.

The preload on the LSD in new unused state is 80N.m, with a tolerance of -1.5N.m, + 10N.m. The adjustment of the pre-load is made with different thickness "Belleville" spacers. - Their characteristics are the following:

- 1,60mm (ref. 77 11 154 922)
- 1,85mm (ref. 77 11 154 921)
- 2,00mm (ref. 01 00 085 912)

NOTA: The preload on the LSD is measured with a torque wrench. The gearbox is in neutral, one wheel is blocked and measurement taken on the other wheel.

It is normal for the preload on the LSD to reduce by around 30% after a period of use.

GEARBOX

Gear ratio diagrams

Short ratios

	FINAL RATIO: 3,1					
	I	II	III	IV	V	VI
Ratio:	12/36	16/36	16/29	18/27	21/27	23/36
	3,00	2,25	1,81	1,50	1,28	1,13
Speed drop:	-	1800	1400	1241	1056	844
Speed in rpm 7200	83,14	110,85	137,61	166,28	194,86	220,72

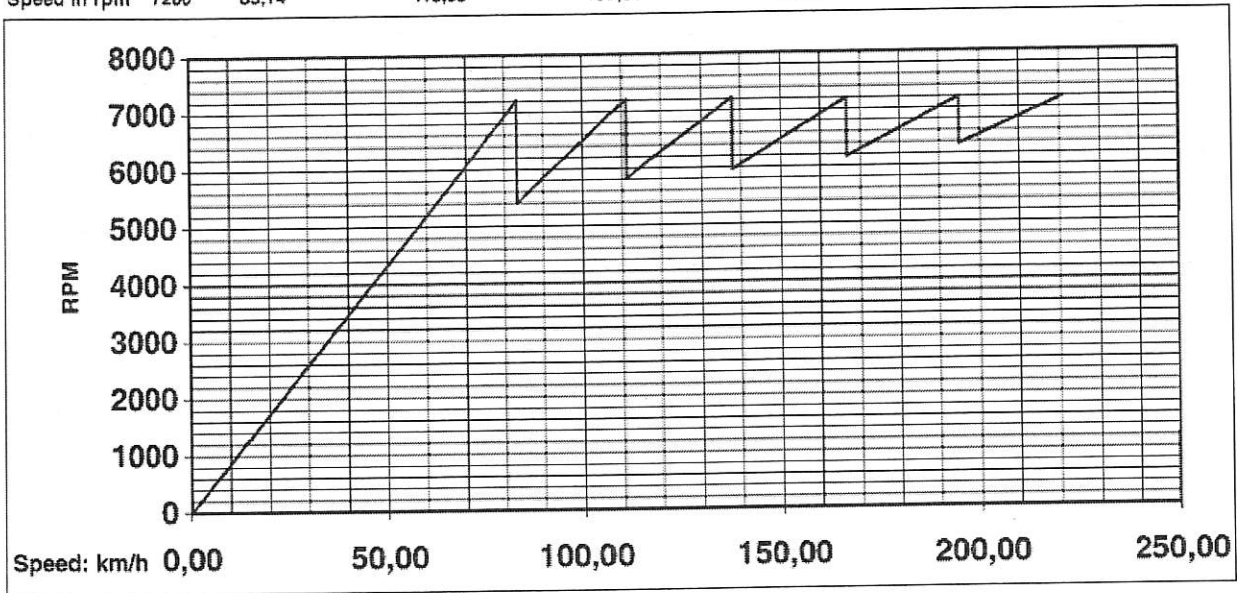

Medium ratios

	FINAL RATIO: 3,1					
	I	II	III	IV	V	VI
Ratio:	12/34	17/36	19/32	20/28	20/24	22/23
	2,83	2	2	1	1	1
Speed drop:	-	1831,80	1467,30	1200,00	1028,57	960,00
Speed in rpm 7200	88,13	118,21	148,46	178,16	207,85	239,82

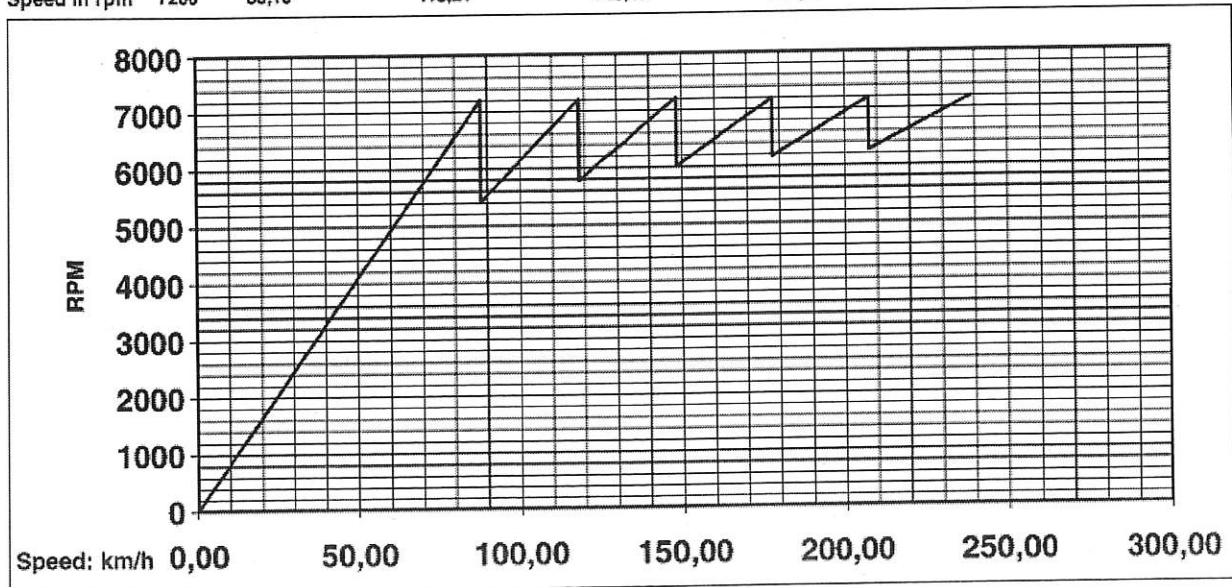

GEARBOX

Gear ratio diagrams

Long ratios

	FINAL RATIO: 3,1					
	I	II	III	IV	V	VI
Ratio:	14/37	18/35	18/28	21/27	20/22	27/26
	2,64	1,94	1,55	1,28	1,10	0,96
Speed drop:	-	1909	1447	1254	1013	916
Speed in rpm 7200	94,48	128,57	160,91	194,86	226,74	259,81

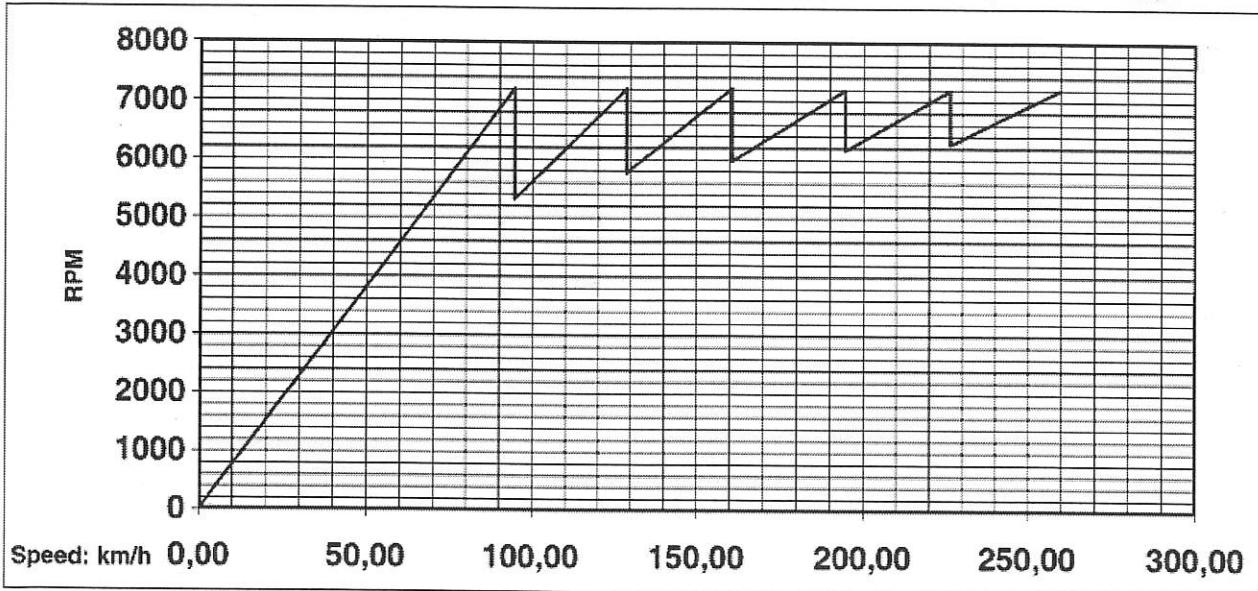

Capacity: 1,7L.

Draining :

- 1st fill: After the first kilometres.
- Frequency: After every race.

Oil : Elf HTX 752 SAE 80W140

Level :

- Adjust the oil level to the opening (1).

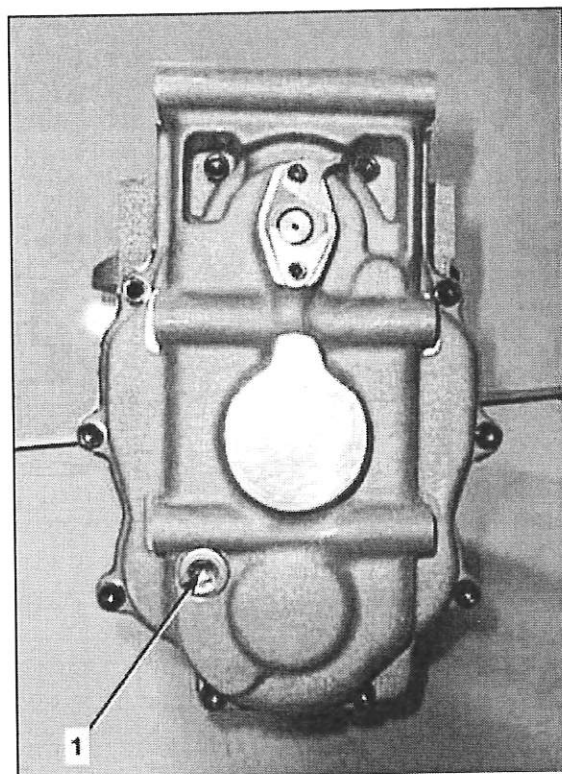

SPECIAL PRECAUTIONS

No additives should be added to the oil. The resulting consequences are not in any circumstances covered by the SADEV supplier.

When topping up the gearbox oil, do not mix any other oil with that already in the box.

STORAGE AND USE

Be particularly careful with any bottles, which are open when used:

- Close the bottle again properly after use to prevent the introduction of water or dirt.
- Store bottles horizontally, protected from severe weather.
- Do not store bottles close to a washing station.
- Do not decant the oil into larger containers.

PRESSURE WASHING

When the gearbox is removed, seal all openings correctly to prevent the ingress of water into the gearbox.

GEARBOX Products





21

TYPE	ELEMENT
LOCTITE strong Thread lock 270	Primary shaft bolts Secondary shaft nut Reverse rocker bolt Barrel retainer bolt
LOCTITE normal Thread lock 243	Crown bolt
LOCTITE sealant 577	Reverse pin anti-rotation bolt RENAULT elbow connector
LOCTITE low Thread lock 222	Upper and lower closing plate bolt Left/right plate bolt Control closing block bolt
LOCTITE Bloypress 648	Secondary fixing shaft bolt Bevel gear bearing bolt
LOCTITE Bloypress 601	Ring Permaglide
LOCTITE gasket paste 518	Contact faces between gearbox and cover
Dow Corning 732	Contact faces between rear housing and gearbox

GEARBOX

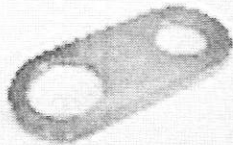
Special tools

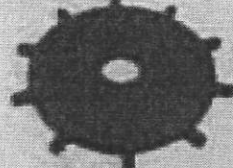
21

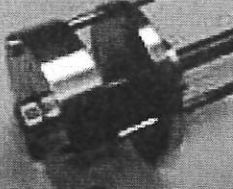
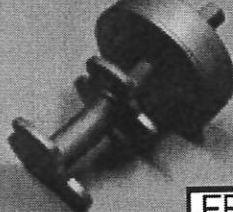
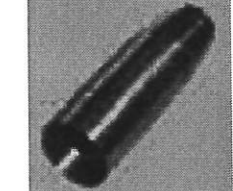
TOOLS	METHODS REF.	M.P.R. N°	DESCRIPTION
	Ref. SADEV	OUT 0085001	Locking plate
	Ref. SADEV	OUT 0085002	Clutch plate centring pin
	Ref. SADEV	OUT 0085003	Fork repositioning tool
	Ref. SADEV	OUT 0085004	Play adjuster
	Ref. SADEV	OUT 0085005	Spacer
	Ref. SADEV	OUT 0085006	Roller cage positioning cage
	Ref. SADEV	OUT 0085007	LSD preload tester
	Ref. SADEV	OUT 0085009	Tool for installing lip seal
	Ref. SADEV	OUT 0085010	Anti-rotation pin for LSD
	Ref. FACOM	U.49D6	Bearing extractor
	Ref. FACOM	U.306G2 U.306M	Inertia extractor

GEARBOX

Tightening torques

21

Indexing bolt: 13N.m
LOCTITE low-strength threadlock 222

Pusher guide bolt: 6N.m
LOCTITE low-strength threadlock 222

External transfertshaft bolt:
22N.m
LOCTITE normal threadlock 243

Face joint
between rear
casing and
gearbox: Dow
Corning 732

Rear casing
bolt: 22N.m
LOCTITE
low-strength
threadlock 222

Push-pull lock
bolt: 25N.m
LOCTITE
low-strength
threadlock 222

Oil seal plate bolt: 6N.m
LOCTITE low-strength threadlock 222

Right hand plate bolt: 25N.m
LOCTITE low-strength threadlock 222

Control closing block bolt: 6N.m
LOCTITE low-strength threadlock 222

Reverse rocker bolt: 55N.m
LOCTITE high-strength threadlock 270

Reverse pin anti-rotation bolt: 22N.m
LOCTITE sealant 577

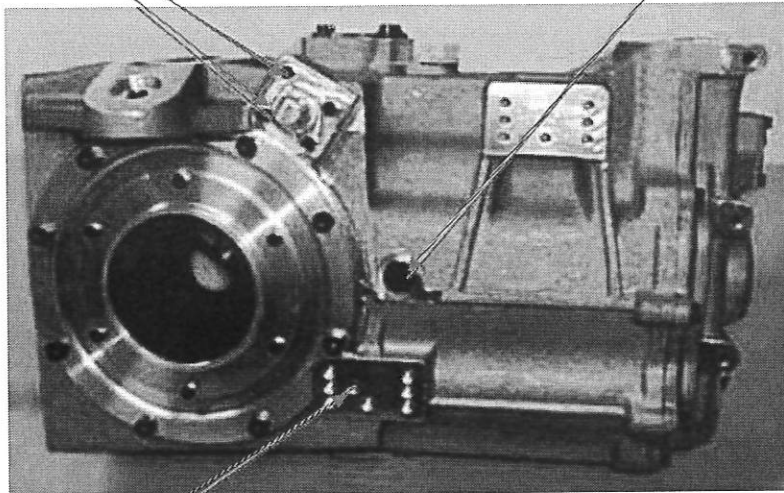
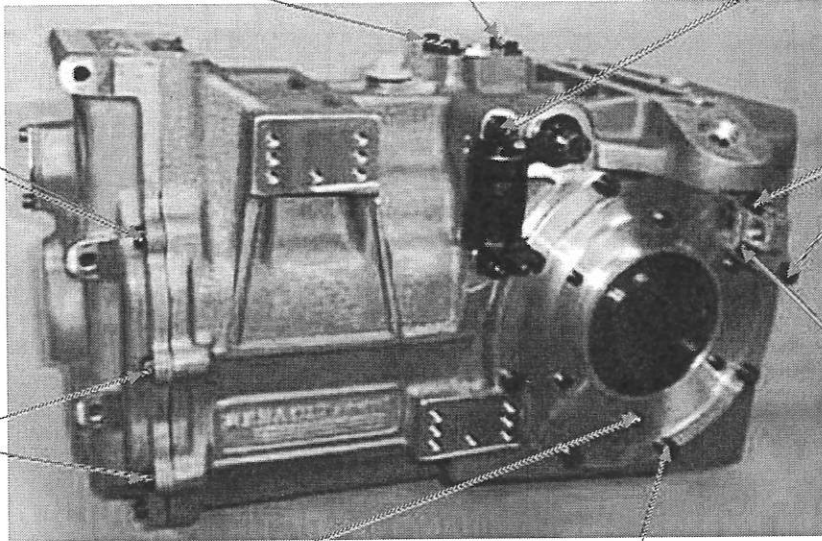

GEARBOX

Tightening torques

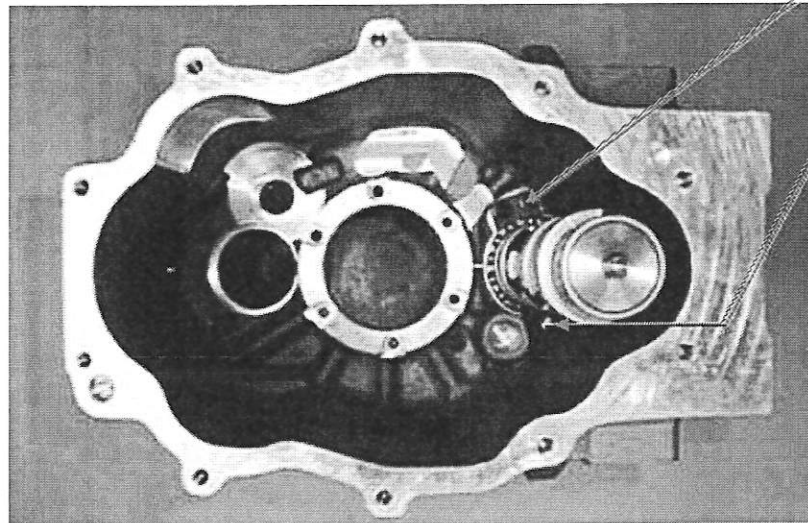

Barrel retainer bolt:
22N.m
LOCTITE normal
threadlock 243

Secondary shaft nut: 180N.m
LOCTITE high-strength threadlock 270

Primary shaft nut: 100N.m
LOCTITE high-strength threadlock

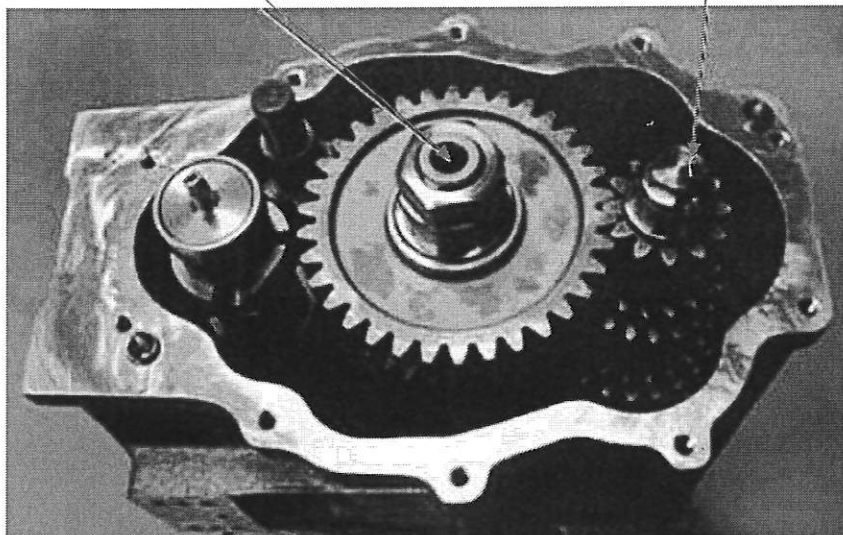

GEARBOX

Tightening torques

Bevel gear bearing
bolt: 15N.m
LOCTITE normal
Threadlock 243

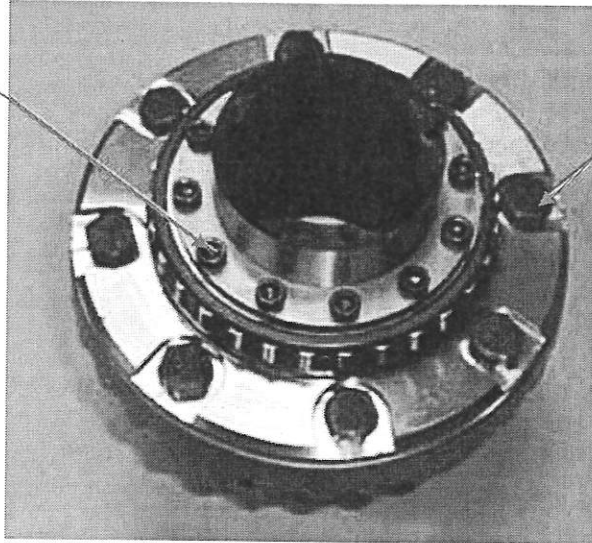

Crown bolt: 90N.m
LOCTITE
Blocpress 648

Joint face on upper and lower plates
LOCTITE gasket paste 518

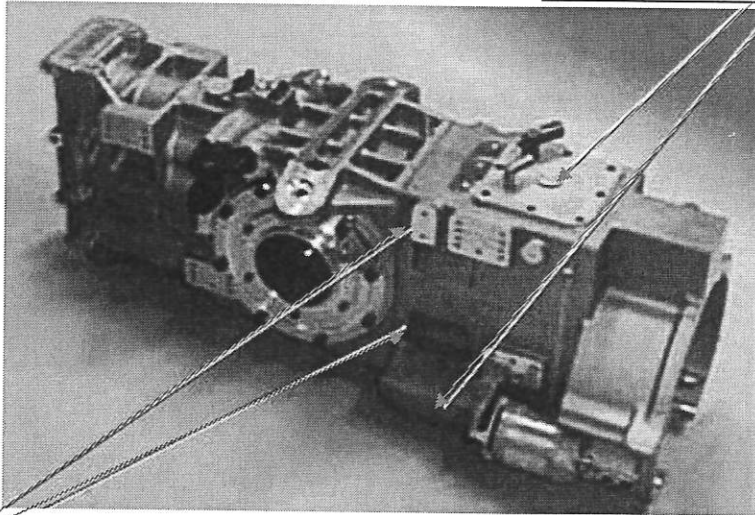

Joint face between casing and gearbox:
LOCTITE gasket paste 518

GEARS

Removal

- Engage reverse gear.
- Drain gearbox through lower drain plug.
- Disconnect potentiometer.
- Remove rear casing and clean magnet (1).
- Remove fork shaft (1) and swing forks to release barrel slope control fingers.

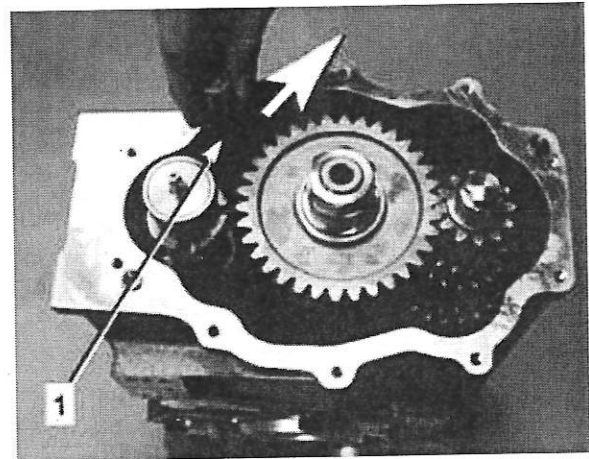
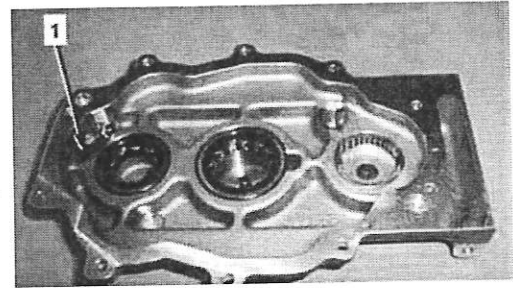

- Engage 2nd gear.
- Fit primary and secondary shaft lock plate OUT 0085001.
- Remove primary shaft bolt (right-hand thread) (1) and secondary shaft bolt (left-hand thread) (2).

NOTA: These bolts are glued and a hot air gun must be used.

- Remove gears one after the other marking installation direction.

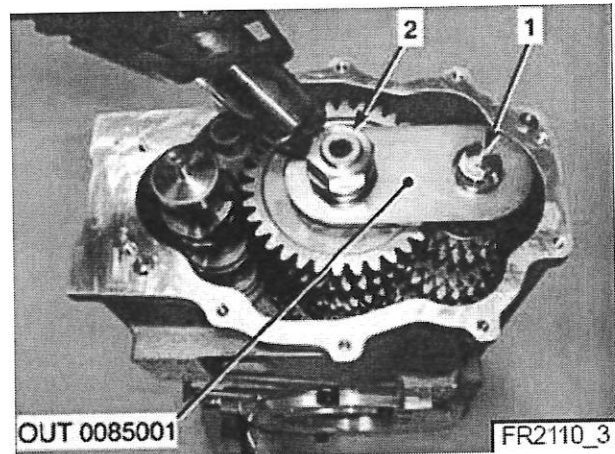

Installation

IMPORTANT: Do not invert the gears to ensure their initial rotation direction: risk of breaking teeth.

- Clean and check condition of parts.
- Lightly lubricate the needle roller bearing cages using gearbox oil (1).
- Replace gears one after the other in the reverse order from removal.
- Engage 2nd gear to prevent gearbox turning.

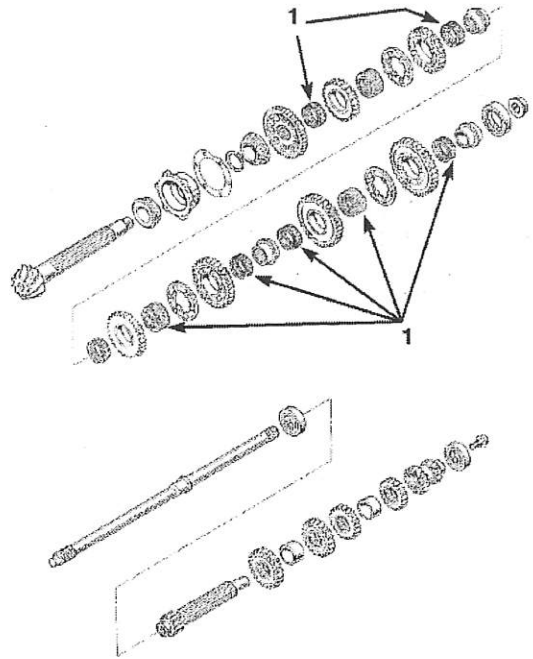

- Mount the primary/secondary lock plate OUT 0085001.
- Clean and degrease threads on shafts and bolts.
- Coat primary shaft bolt (1) and thread of secondary shaft (2) with LOCTITE Thread lock 270 and tighten to torques:
 - primary shaft bolt: 100N.m,
 - secondary shaft nut: 180N.m.

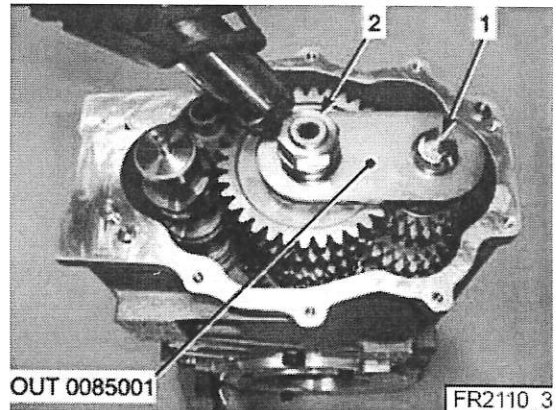

- Replace forks in initial locations using the fork-repositioning tool OUT 0085003.
- Clean the joint face of the rear casing (1).
- Coat the joint face with Dow Corning gasket paste 732.
- Connect potentiometer and ensure that its coupling is still correct: the gear display must indicate reverse.
- Refit rear casing.
- Top up gearbox oil to level stop.

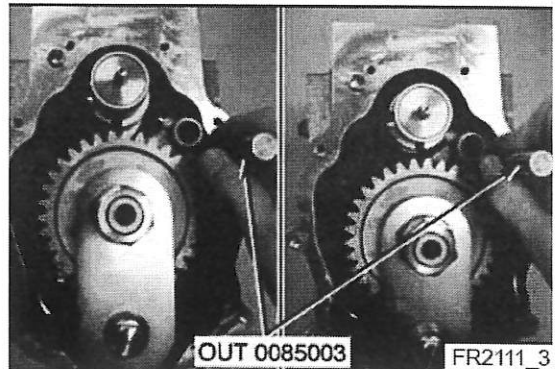

LIMITED SLIP DIFFERENTIAL

Removal of the LSD (without affecting the bevel crown gear)

- Remove only the left-hand oil seal plate (1).

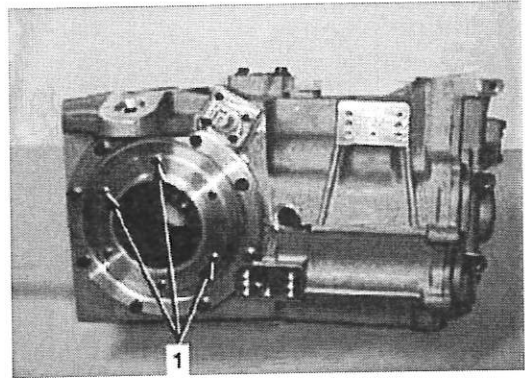

NOTA: Make the two tapped holes (1), as shown in the figure, to make disassembly easier. It is compulsory to observe the dimensions listed.

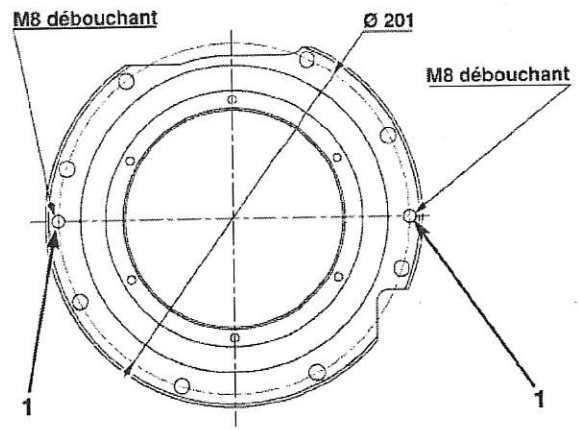

Dismantling of the LSD

- Remove the bevel gear bearing (1).

NOTA: The bolts are glued and a hot air gun must be used.

- Remove bevel gear (2).
- Remove the LSD elements (3) one after the other, noting the refitting sequence.
- Check condition of the various parts and housing. Replace faulty parts.

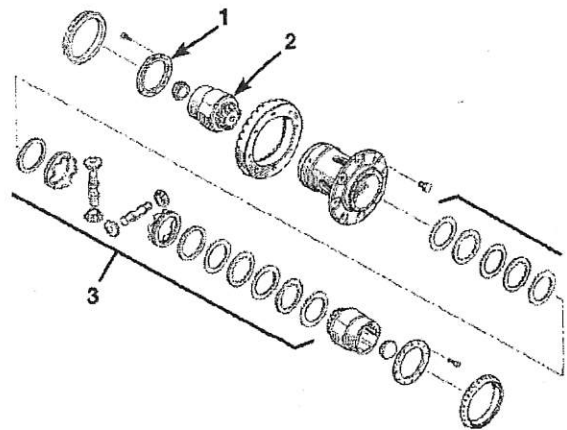

Refitting of the LSD

- Clean parts.
- Using an M6x100 tap, clean and degrease the threads on the casing and bolts.
- Replace parts in the reverse order of installation, lubricating each part with gearbox oil just before installation.
- Maintain order of parts as noted during dismantling.
- Fix the bevel gear bearing (1) on the housing using bolts coated with a few drops of LOCTITE normal Thread lock 243, tighten bolts to 15N.m.
- Check good operation of LSD. Check preload on LSD:
 - fit tool OUT 0085010 on one of the two hollow bevel gears in order to prevent the diff. from turning,
 - check the preload by using a torque wrench and tool OUT 0085007 positioned on the second bevel gear,
 - this must be between 65N.m and 90N.m for a new diff. and between 40N.m and 50N.m for a used diff.
- Check the preload.
- If the preload is different from required, replace the spring washers by other ones (with different thickness). Three different thicknesses are available: 1.6, 1.85, and 2mm.

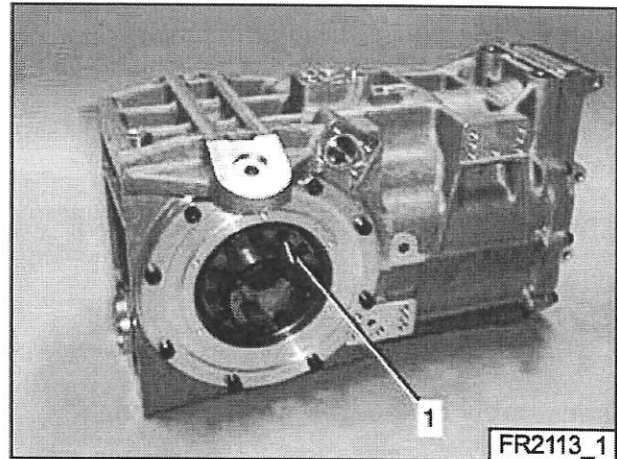

IMPORTANT: Check the real dimensions of the parts before mounting them : The minimum dimensions below must be respected :

- Spring washers : nominal thickness -0.08mm
- Smooth discs : -0.06mm
- Friction discs: +0.05 / -0,1mm

For information, for a used LSD:

- Brand new smooth discs (1.85mm thick) and friction discs (2mm thick) + 1.6mm spring washer 5m.kg preload.
- Mid-used smooth and friction discs + 1.85mm spring washer 4m.kg preload.
- Used smooth discs (1.79mm) + used friction discs (1.94mm thick) + 2mm spring washer 4.5m.kg preload.

Refitting of the LSD

- Clean the joint face of the oil seal plate.
- Using an M5x80 tap, clean and degrease the threads on the casing and bolts.
- Check condition of O-ring seal and lip seal.
- Attach the oil seal plate to the gearbox using bolts coated with a few drops of LOCTITE low-Thread lock 222. Tighten bolts to 6N.m.

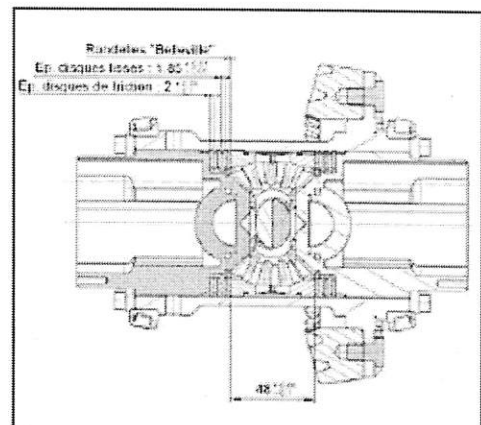

Removal of the LSD crown wheel

- Drain the box through the lower drain plug.
- Remove the right-hand (remove push-pull stop tripod) and left-hand oil seal plates (1).
- Remove left-hand plate (2).
- Extract the LSD assembly.

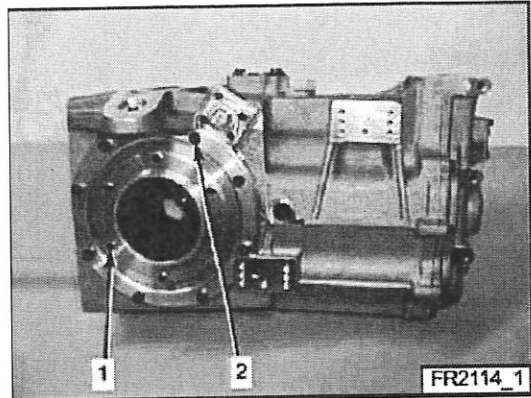

Disassembly of the LSD crown wheel

- Remove the right-hand bevel gear bearing (see corresponding paragraph).
- Remove right-hand tapered roller bearings (2).
- Remove crown wheel fixing bolts (1).

NOTA: The bolts are glued and a hot airgun must be used.

Re-assembly of the LSD crown wheel

- Using an M 10x100 tap, clean and degrease gearbox and bolt threads.
- Attach the crown wheel to the housing using bolts coated with a few drops of LOCTITE Bloypress 648. Tighten bolts to 90N.m.
- Replace bearing then bevel gear bearing (see corresponding paragraph).
- Adjust the various plays: bearing preload, check tothing play (see corresponding paragraph on removing secondary shaft).

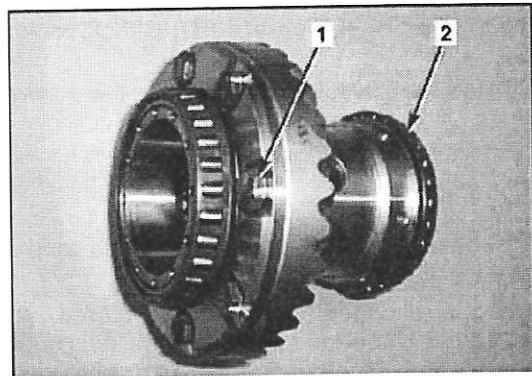

Re-fitting of the LSD crown wheel

- Clean joint face on left-hand plate (1).
- Using an M8x125 tap, clean and degrease for housing and bolt threads.
- Check condition of O-ring.
- Attach left-hand plate to gearbox using bolts covered with a few drops of LOCTITE low-strength Thread lock 222. Tighten bolts to 25N.m, while turning the differential in order to position the tapered roller bearings properly.
- Using an M5x80 tap, clean and degrease gearbox and bolts of the oil seal plate.
- Attach oil seal plates to the casing using bolts coated with a few drops of LOCTITE low-strength Thread lock 222. Tighten bolts to 6N.m.
- Check condition of O-ring and lip seal. Top up oil in the gearbox to the stop level

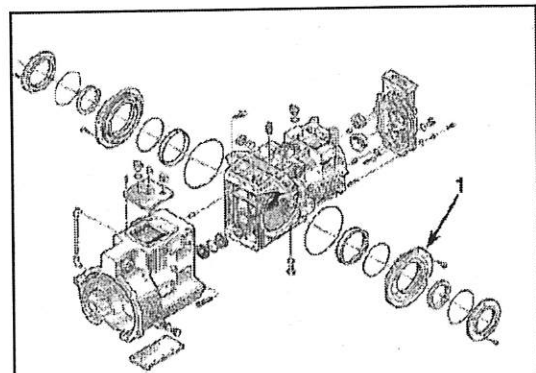

REPLACEMENT AND ADJUSTMENT OF VARIOUS BEARINGS

Removal of primary shaft bearing

Rear casing side:

- Drain oil through the lower drainage plug.
- Disconnect potentiometer and remove assembly from support.
- Remove rear casing.
- Remove lip seal from potentiometer - Heat rear casing to 120°C.
- Fit an extractor U.49D6 (1) on the primary shaft bearing and extract using an inertia extractor.

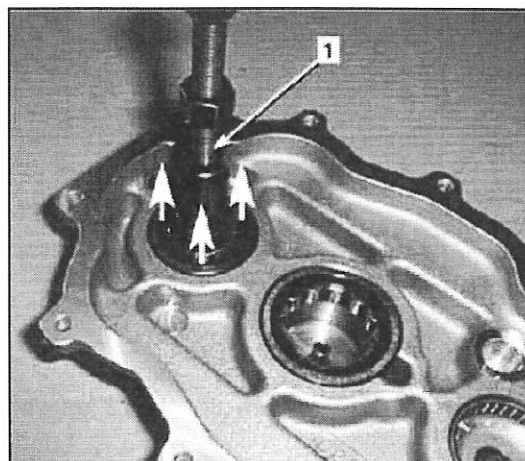

NOTA: Check that the bearing housing has not been damaged on dismantling.

Differential side:

- Drain the box through the lower drain plug.
- Disconnect potentiometer and remove assembly from its support.
- Remove rear casing.
- Remove gears (see corresponding paragraph).
- Remove primary shaft.
- Remove LSD assembly (see corresponding paragraph).
- Remove bearing by tapping from the inside of the differential casing.

NOTA: Check that the bearing housing has not been damaged on dismantling.

Refitting of primary shaft bearing

- Apply a small quantity of LOCTITE "fixing product" 603 on the outer bearing cage.
- Press fit the bearing of the rear casing taking care to seat this well at the bottom of its housing.
- For the other bearing use the same glue but do not press fit.

Removal of the secondary shaft bearing

- Remove the potentiometer lip seal - Heat the rear casing to 120°C.
- Turn casing and position on a flat surface, and then tap with a mallet on the back of the secondary shaft bearing housing until the bearing is removed from its position.

NOTA: Check that the bearing housing and spline have not been damaged on dismantling.

Refitting the secondary shaft bearing

- Refit spline (1) at the bottom of the bearing housing.
- Apply a small quantity of LOCTITE "fixing product" 603 on the outer bearing cage.
- Press fit bearing on the rear casing ensuring this is well seated at the bottom of its housing.
- Install the bearings on the differential side (see corresponding paragraph).

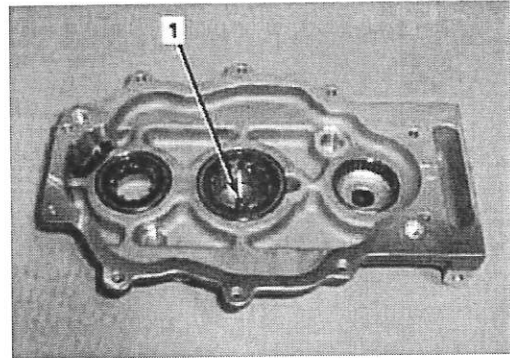

Removal of the rear casing side barrel bearing

- Remove the potentiometer lip seal.
- Heat the casing to 120°C.
- Position the extractor U.306G2 (1) in the recesses on the housing and extract the bearing using the inertia extractor.

NOTA: Check that the bearing housing has not been damaged on dismantling.

Refitting the rear casing side barrel bearing

- Apply a small quantity of LOCTITE "fixing product" 603 on the outer bearing cage.
- Press fit the bearing on the rear casing ensuring this is properly seated at the base of its housing.

IMPORTANT: On refitting, ensure that the needle roller cage has not been crushed (rotate the needles).

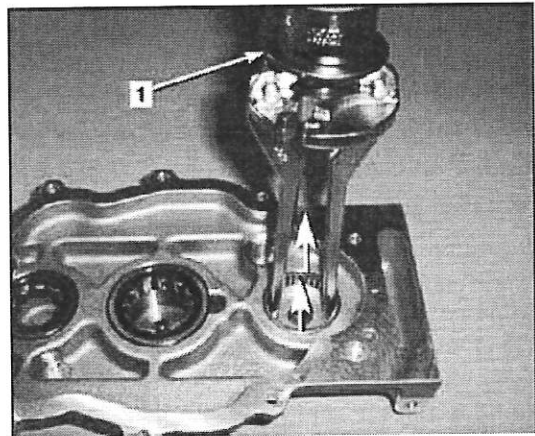

Removal of the differential side barrel bearing

- Drain the box through the lower drain plug.
- Disconnect potentiometer and remove from support.
- Remove rear housing.
- Remove gears (see corresponding paragraph).
- Remove reverse rocker (see corresponding paragraph).
- Remove indexer guide.
- Remove the three bolts (1) on the barrel-bearing retainer and extract the barrel.
- Remove barrel clip.
- Remove press bearing (do not damage barrel).

NOTA: Check that the bearing housing has not been damaged on dismantling.

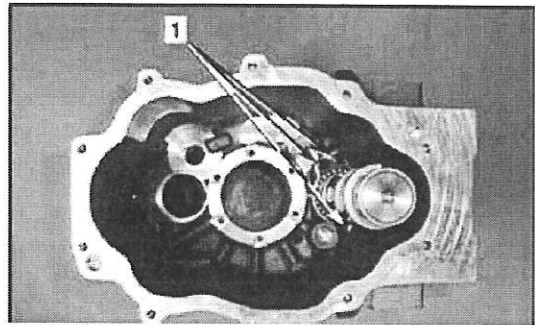

Refitting of the rear casing side barrel bearing

- Apply a small quantity of LOCTITE "fixing product" 603 on the inner bearing cage.
- Press fit the bearing on the barrel.
- Refit clip.
- Refit barrel (see corresponding paragraph).

Removal of the differential bearing

- Drain the box through the lower drain plug. Remove gears (see corresponding paragraph).
- Remove right-hand (remove the push-pull locking tripod) and left-hand oil seal plates.
- Remove right-hand and left-hand plates. Extract the LSD assembly.
- Remove left-hand and right-hand bevel gear bearings and LSD elements (see corresponding paragraph).
- Remove right-hand and left-hand tapered roller bearings.
- Separate bearing shells and shims for the right-hand and left-hand plates.
- Remove secondary shaft (see corresponding paragraph).

Refitting of the differential bearing

- Press fit the tapered roller bearings on the LSD casing.
- Refit the bearing shells and shims on the left-hand and right-hand plates.
- Refit the LSD assembly (see corresponding paragraph).

Check preload on differential bearings

- Refit right-hand and left-hand plates without glue and tighten bolts to 25N.m.
- Check the preload on the LSD bearings using a torque wrench and a tool OUT 0085007 to measure the load necessary for rotation. This must be between 3,4kg and 6kg for new bearings and between 0,2kg and 1,6kg for used bearings.
- If the preload obtained is not in this range, remove the right-hand and left-hand plates and bearing shells (1), and adjust thickness of the shims (2).
- Refit the plates.
- Rotate the differential to position the tapered roller bearings correctly.
- Check the preload.
- Once the correct preload has been obtained, check the thickness of the two shims.
- Refit secondary shaft (see corresponding paragraph), and adjust operating play on the conical pair (see corresponding paragraph).

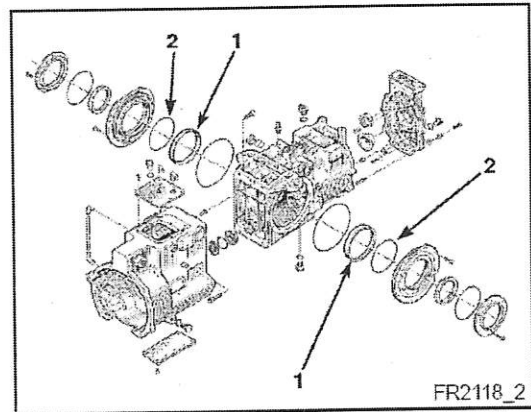
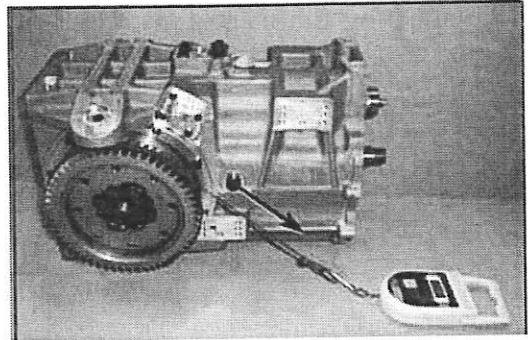

ADJUSTMENT OF OPERATING PLAY ON CONICAL PAIR

- Drain the box via the lower drain plug.
- Remove gears (see corresponding paragraph).
- Fit tool OUT 0085004 and OUT 0085005 on the secondary shaft and tighten the secondary shaft nut to 180N.m.
- Check the inter-tooth play using a comparator placed on tool OUT 0085004 (play indicator).
- Check the play for each tooth on the gear (10 teeth) by rocking the secondary shaft from left to right. The play must be between 0,1mm and 0,2mm.
- If the inter-tooth play is incorrect, remove the oil ring plates and the right-hand and left-hand plates, remove the shims behind the bearing shells and proceed as follows:
 - If the play is excessive, move the crown wheel closer to the pinion by increasing the thickness of the left-hand shim and reducing the thickness of the right-hand shim accordingly.
 - If the play is sufficient, move the crown wheel away from the pinion by reducing the thickness of the left-hand shim and increasing the thickness of the right-hand shim accordingly.
 - Recheck play.

IMPORTANT: Keep the total thickness of the two shims constant so as not to affect the preload on the bearings.

- Once the play has been checked, refit the LSD (see corresponding paragraph).
- Refit gears (see corresponding paragraph).

SECONDARY SHAFT

Removal

- Drain the box through the lower drain plug.
- Remove gears (see corresponding paragraph).
- Remove LSD (see corresponding paragraph).
- Remove secondary shaft fixing bolts (4).
- Remove secondary shaft by tapping on its end with a mallet (do not damage the thread) and withdrawing this through the differential housing.
- Withdraw bearing (2), and preload brace (3).
- Remove bearing cage by heating the casing uniformly to 120°C around the zone concerned.

NOTA: Check that the bearing housing has not been damaged on dismantling.

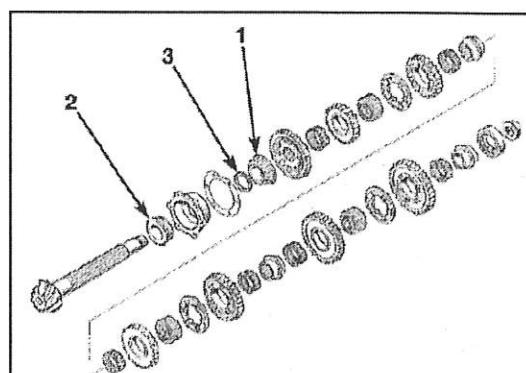
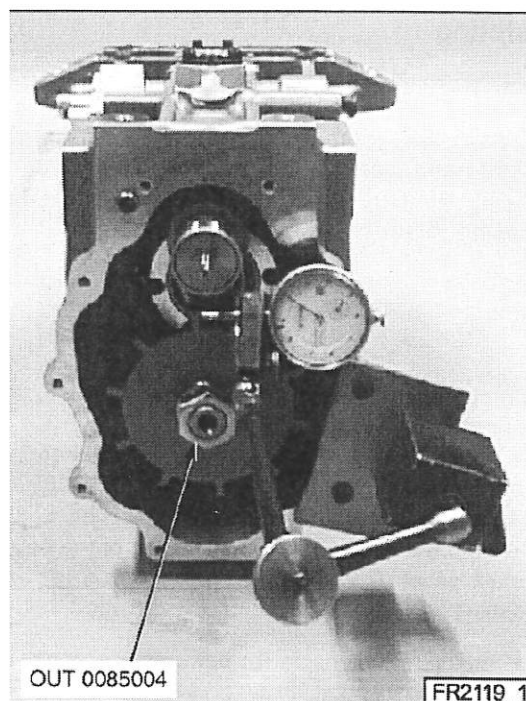

Refitting

- Using an M7x100 tap, clean and degrease the bearing cage threads and bolts.
- Clean the joint faces of the left-hand and right-hand plates.
- Using an M8x125 tap, clean and degrease the casing threads and bolts.

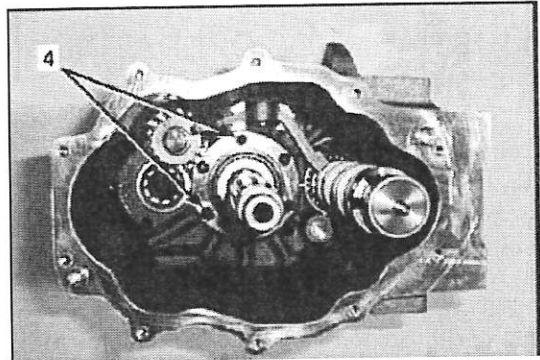

- Calculate advance and thickness e (5) of the shims:
 - Press fit the preload assembly of brace bearing case on the secondary shaft. Fit brace OUT 0085005 and tighten the secondary shaft nut to 180N.m,
 - note the value marked on the top of the secondary shaft pinion (a), and that on the bottom of the LSD casing (c)
 - measure dimension (b) between the upper face of the secondary shaft pinion (1) and the lower face of the bearing cage (2),
 - perform the following operation:

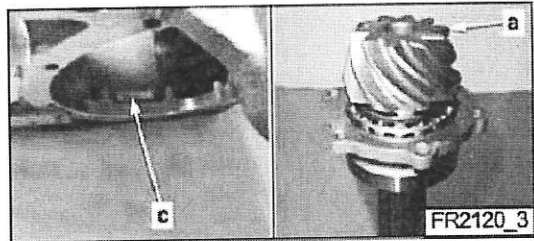

		Example
a	(1)	60,95
b	(2)	48,98
a + b	(3)	109,93
c	(4)	110,449
$e = (4) - (3)$	(5)	0,519

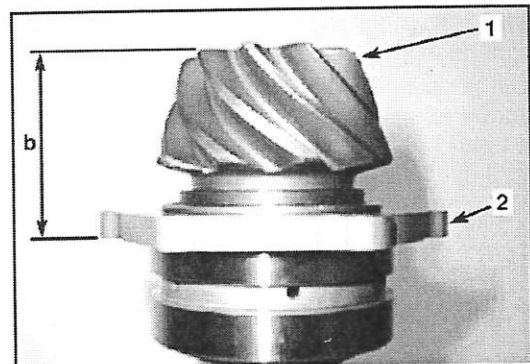

Replace the secondary shaft

- Remove cage and bearing from the secondary shaft (1).
- Fit the back plate (A) of tool OUT 0085006 on the casing.
- Taking care not to damage back plate (A), heat the gearbox casing until the temperature of the roller cage housing is 120°C.
- Fit shim thickness e (B) on the roller cage (C) (see calculation of the previous chapter).
- Position the cage on the centring pins of tool (D) so that its bores coincide with those on the shim and casing (E).
- Fit support plate (F) on tooling.
- Tighten the nut of back plate (A) in contact with the retaining of the bell race (C) with the housing.
- Fit 3 secondary shaft-fixing bolts so that the casing bores align perfectly opposite the cage threads.
- Hold this fixing until the temperature of the casing returns to normal.
- Remove the 3 temporary fixing bolts.
- Refit the secondary shaft fixing bolts coated with a few drops of LOCTITE block press 648.
- Tighten bolts to 30N.m.
- Refit secondary shaft preload brace and bearing (1) on the cage.

NOTA: Ensure that the two tapered roller bearings are in contact with the cage.

- Refit LSD.
- Check the operating play of the conical pair (see corresponding paragraph).
- Top up the gearbox oil to the level.

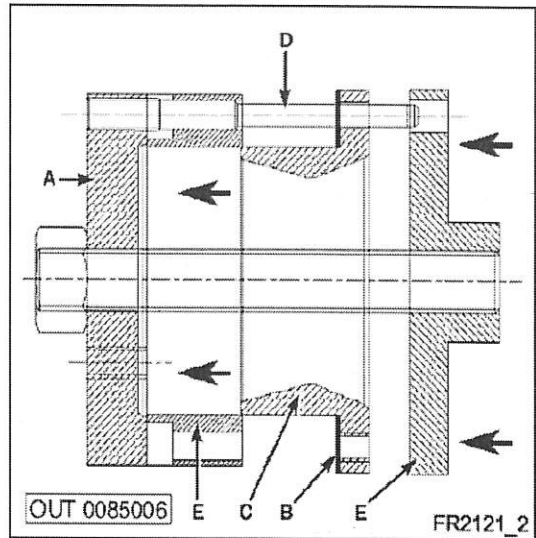

CLUTCH SHAFT

Removal

- Destroy lip seal (1) to remove.
- Remove clip (2) behind the seal.
- Remove clutch shaft.
- Remove clutch shaft bearing.

NOTA: If the clutch shaft is seized in the primary shaft, remove the rear casing and bolt on the primary shaft, then insert a shaft 10 diam. inside the primary shaft and tap the clutch shaft to release.

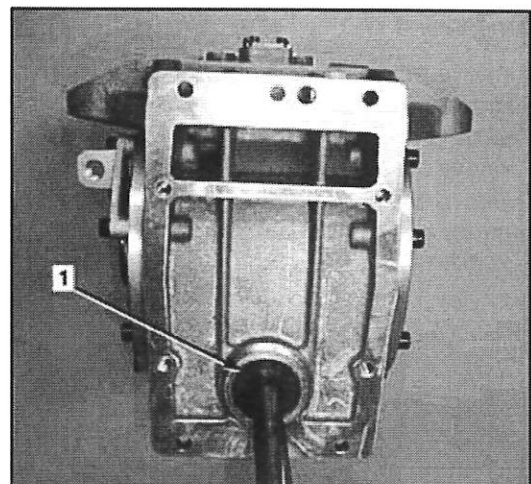

Refitting

- Clean and check state of shaft (splines and bearing surface) and housing of lip seal.
- Change faulty parts.
- Lubricate the bearing surface and shaft splines.
- Fit the ball bearing on the clutch shaft.
- Fit the clutch shaft in the primary shaft and attach with clip (2).
- Apply tool OUT 0085009 on the splines then fit the new lip seal in place.

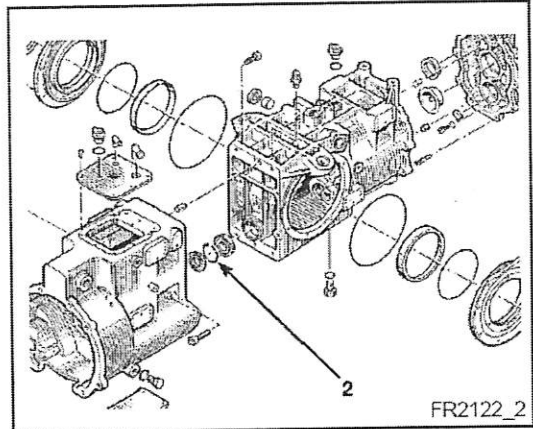

SELECTION

Removing the control lever

- Remove the push-pull cable of the external transfer.
- Remove the two fixing bolts of the external transfer and release from the control lever.
- Remove the reverse gear locking cable. Engage reverse gear using the control lever.
- Remove control-closing block.
- Remove pusher guide.
- Pass a round magnet (1) type FACOM (ref. 827.1) through the opening of the pusher guide and support the double clip.
- While holding the clip raised, pivot the control shaft one-quarter of a turn only and extract from the control closing block side

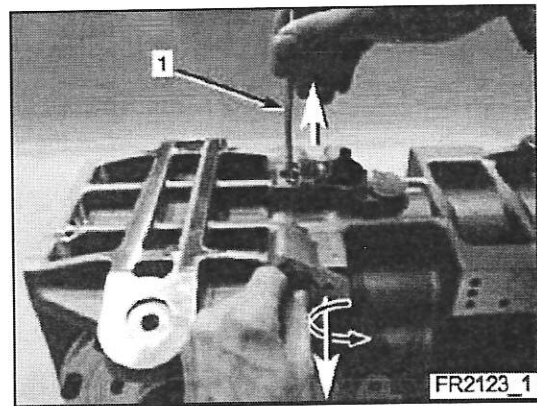

Removal of the selector barrel

- Remove all gears (see corresponding paragraph).
- Remove reverse gear rocker (see corresponding paragraph).
- Remove indexer guide.
- Remove the three bolts (1) of the barrel retainer bearing and extract barrel.

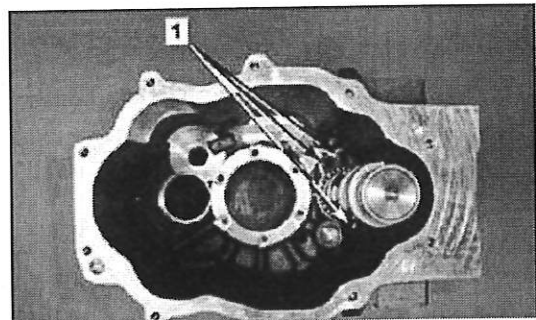

Refit selection barrel

- Proceed in the reverse order from removal.
- Clean and degrease the three fixing bolts (1) of the retainer and the reverse gear rocker bolt.
- Apply a few drops of LOCTITE normal Thread lock 243 on the bearing retainer bolt and LOCTITE high-strength Thread lock 270 on the reverse gear rocker bolt. Tighten as follows:
 - Bearing retainer bolt: 22N.m,
 - Reverse gear rocker bolt: 55N.m.
- Refit indexer guide and tighten bolts to 13N.m, after coating with a few drops of LOCTITE low-strength Thread lock 222.

Refit control lever

- Clean the joint face of the control-closing block.
- Put the barrel in reverse gear position.
- Check the condition of the double clip (1) and control shaft (2).
- Check the good condition of the various O-rings and lip seals.
- Refit the double clip on the control lever.
- Insert control lever in casing having first made a quarter turn anti-clockwise. Once the shaft is in place, turn this back a quarter turn clockwise.
- Using an M5x80 tap, clean and degrease the casing threads and bolts on the pusher guide and control closing block.
- Refit pusher guide. Coat threads with LOCTITE low strength Thread lock 222 and tighten to 6N.m.
- Apply a few drops of LOCTITE low-strength Thread lock 222 on the bolts of the control-closing block and refit block. Tighten bolts to 6N.m.
- Refit reverse gear locking cable on gearbox.
- Clean bolts, coat threads with LOCTITE sealant 577 and tighten bolts moderately.
- Check proper function of gate on selector lever.
- Using an M7x100 tap, clean and degrease the casing threads and bolts of the external transfer lever.
- Apply a few drops of LOCTITE normal Thread lock 243 and tighten the bolts on the external transfer lever to 22N.m.
- Refit push-pull cable on external transfer.

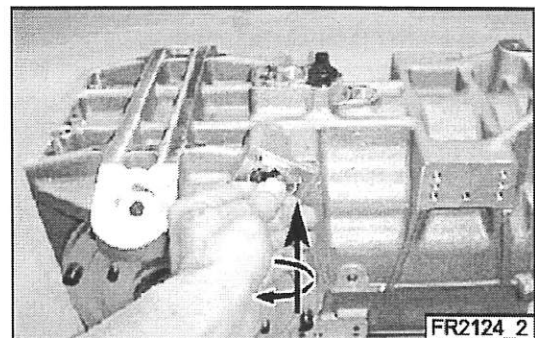
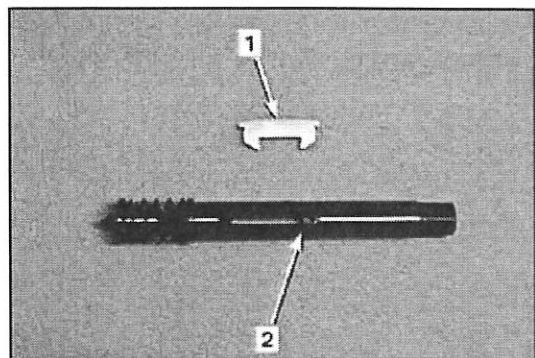

REVERSE GEAR

Remove reverse gear transfer pinion

- Remove all gears (see corresponding paragraph).
- Withdraw primary shaft.
- Withdraw cover on rocker bolt (1).

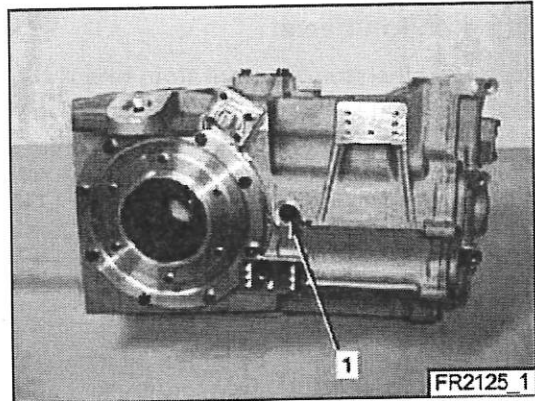

- Using an open-ended wrench, stop the reverse rocker nut turning (1) and release rocker bolt.
- Withdraw rocker (2) and reverse transfer pinion (3).

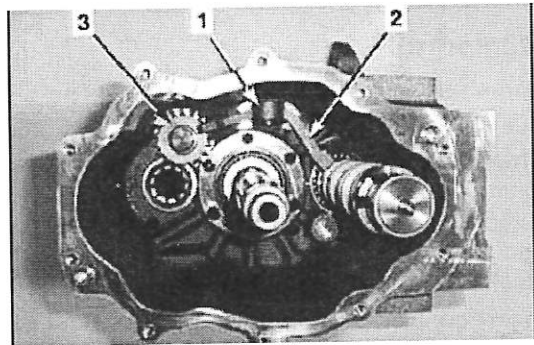

Remove reverse pin

- Remove LSD (see corresponding paragraph).
- Remove anti-rotation bolt of reverse pin (1).
- Heat the casing to 120°C around the reverse pin.
- Remove the pin from the LSD casing side by tapping with a mallet.

NOTA: Check that the bore of the casing has not been damaged.

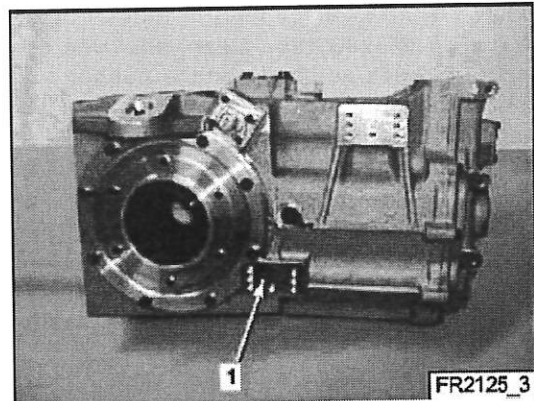

Refit reverse pin

- Check condition of all parts and using an M8x125 tap, clean the anti-rotation bolts of the reverse pin and the threads.
- Heat casing to 120°C around the reverse pin.
- Install (in its original direction) the reverse pin so that the centre point on the reverse pin corresponds with the axis of the anti-rotation bolts (1).
- Refit shaft by tapping with a mallet in the opposite direction to removal.
- Apply LOCTITE sealant 577 to anti-rotation bolts and refit in their initial positions checking that the bolt with the pointed end is positioned in the centring point of the pin. Tighten bolts to 22N.m.
- Refit LSD assembly.

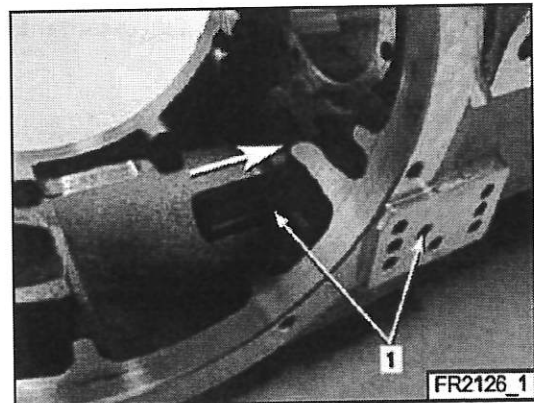

Refit reverse gear transfer pinion

- Clean and check condition of parts.
- Fit the reverse transfer pinion in the fork of the reverse gear rocker.
- Insert the rocker control finger in the barrel groove.
- Using an M10x150 tap, clean and degrease the reverse gear bolt and nut.
- Change the copper washer after each removal.
- Apply a few drops of LOCTITE high-strength Thread lock 270 to the rocker bolt. Tighten the bolt to 55N.m while stopping the reverse nut from turning with an open-ended spanner.
- Refit the bolt head cap.

SETTING THE POTENTIOMETER

- Set the gearbox-shifting lever to reverse.
- Switch on ignition.
- Slightly loosen two screws (1).
- Turn potentiometer body until the dashboard displays letter "R".
- Tighten the two potentiometer-attaching screws (1).
- Engage gears, one after the other, and check that the display on the dashboard corresponds.
- If the display indicate the number "3" in 6th gear, repeat adjustment procedure.

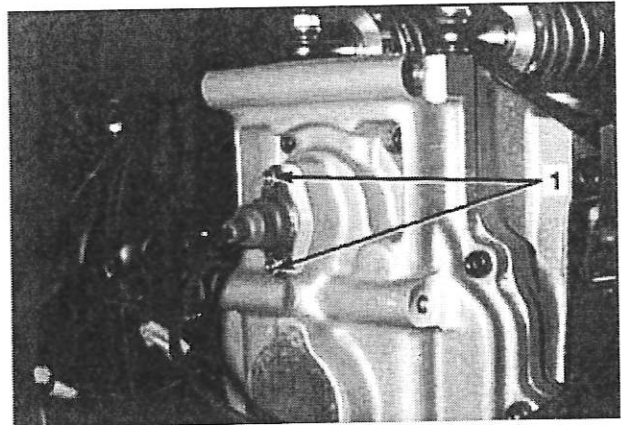

SETTING THE ENGINE SHUTDOWN SWITCH

Engine shutdown switch (1) is set by means of shims (2) fitted between switch (1) and casing.

A set of four 0,25mm pitch shims is delivered along with the gearbox.

To obtain a very accurate adjustment, shim thickness must be minimum.

- Increase shim thickness if the engine untimely shuts down.
- Decrease shim thickness if the gears do not easily disengage.

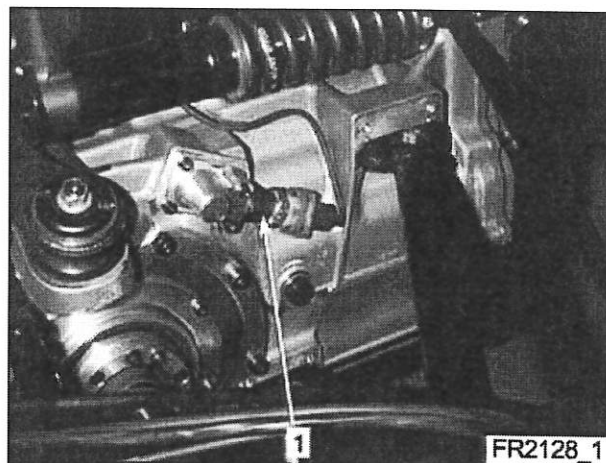

Tightening torque values

Ball joint screw on gearbox: 22N.m.

REMOVAL

On gearshift lever

- Remove sheath stop screw (2).

NOTA: This screw is inserted in the middle of the sheath stop mounting bolt. The sheath stop (2) has three mounting positions. Mark its position if it has to be removed.

- Disconnect ball joint (1) from gearshift lever.
- Remove ball joint.

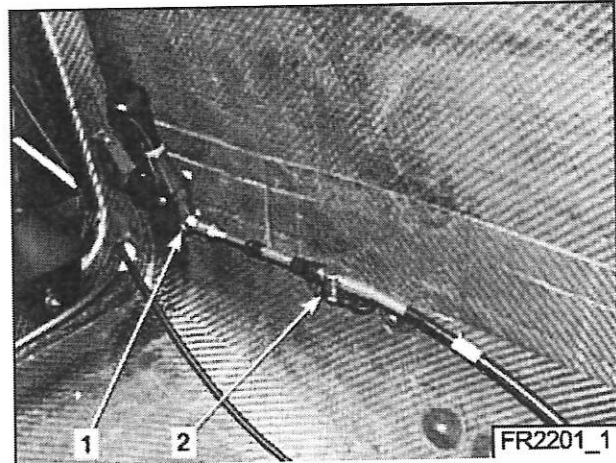

On gearbox

- Disconnect ball joint (1).
- Unscrew control cable from its mounting (2). Remove cable.
- Check play of ball joints. Replace if necessary.

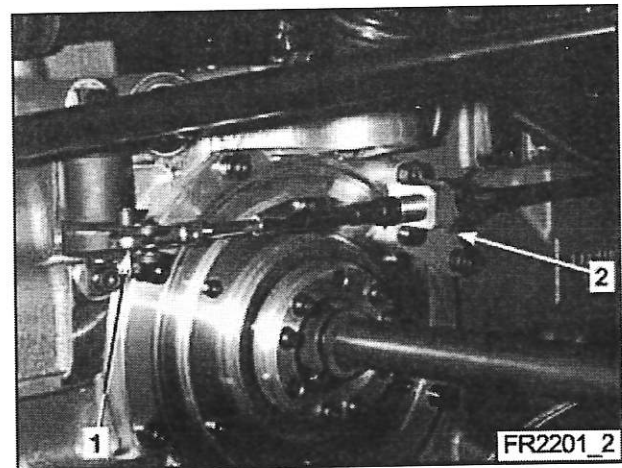

REFITTING

- Repeat the above steps in the reverse order.

ADJUSTEMENT

- Disengage protective sheath (1).

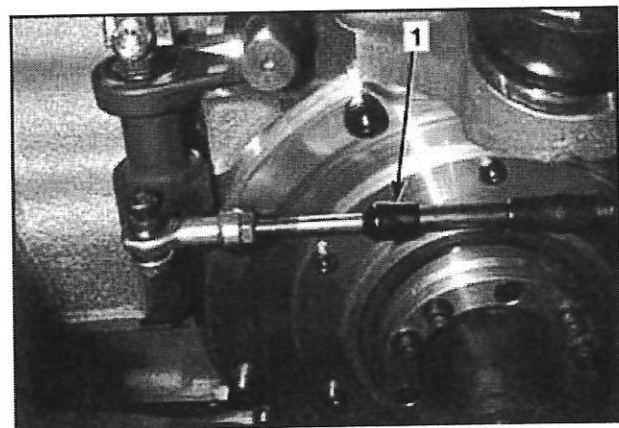

GEAR MECHANISM

Control cable

22

- Make sure that dimension (A) is between 2mm and 50mm.
- Torque bolts to recommended torque.

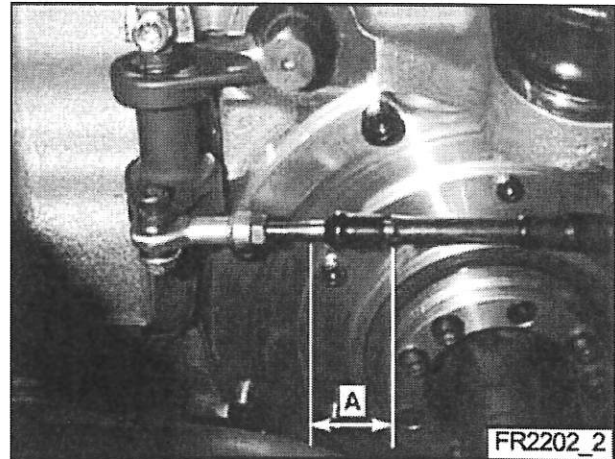

NOTA: The installation of thermal protection of sleeve type is authorized.

REMOVAL

On gearbox

- Unscrew brass screw (1).
- Disconnect cable from gearbox.

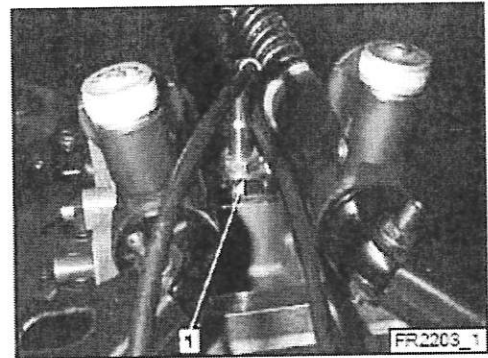

On dashboard

- Loosen locknut (2).
- Remove pull (1) and locknut.
- Loosen locknut behind pair (3).
- Loosen cable on pair.
- Remove cable

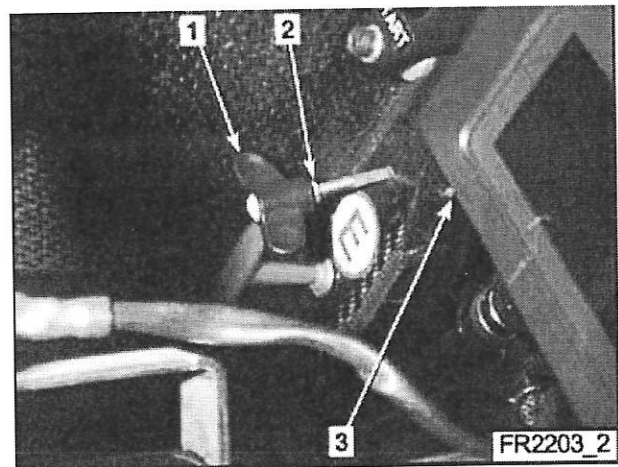

REFITTING

On gearbox

- Clean brass screw. Coat threads with LOCTITE 577 pipe sealant.
- Engage cable in its housing. Slightly tighten brass screw.

On dashboard

- Repeat the disassembly steps in the reverse order.

REMOVAL

- Remove control cable (4) from gearshift lever (see section covering this).
- Remove nut (10), bolt (8), and the two washers (9).
- Remove holder for gearshift lever protective cover.
- Remove bush (1) from holder for gearshift lever protective cover.
- Loosen locknut (2). Remove holder for gearshift lever protective cover (3).

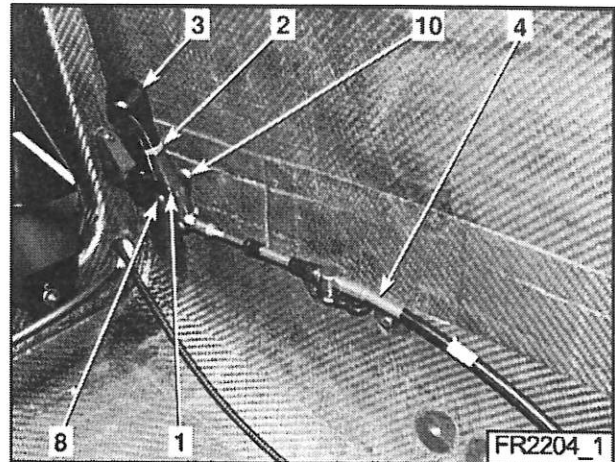

REFITTING

- Assemble lever in reverse order of disassembly.
- Check condition of bush (1). If worn, replace.

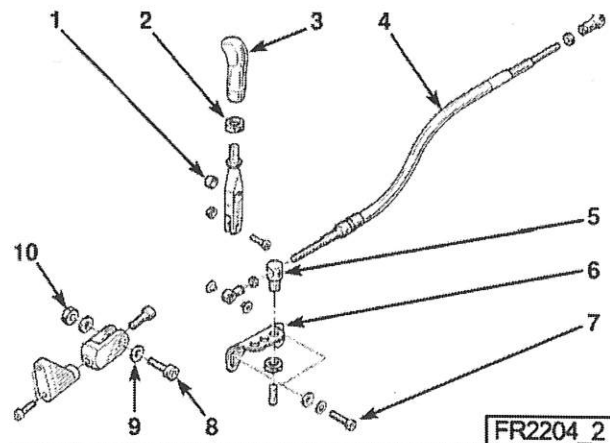

ADJUSTMENT

- Adjust tilt of gearshift lever by positioning cable clamp (5) in one of the three mounting holes (6).
- Loosen screws (7). Correct position of mounting to align cable.

RECOMMENDATION

- In order to improve the reliability of the push-pull cable, we recommend that the gearshift lever is maximum 150mm high.

