

---

	Page
<b>50</b> WIRE	
Overview .....	50-1
Harnesses .....	50-2
Wiring diagrams .....	50-5
Electrical components .....	50-8
<b>52</b> DASHBOARD	
User manual .....	52-1
<b>54</b> BATTERY - FUSE	
Use .....	54-1

## ELECTRICAL INSTALLATION

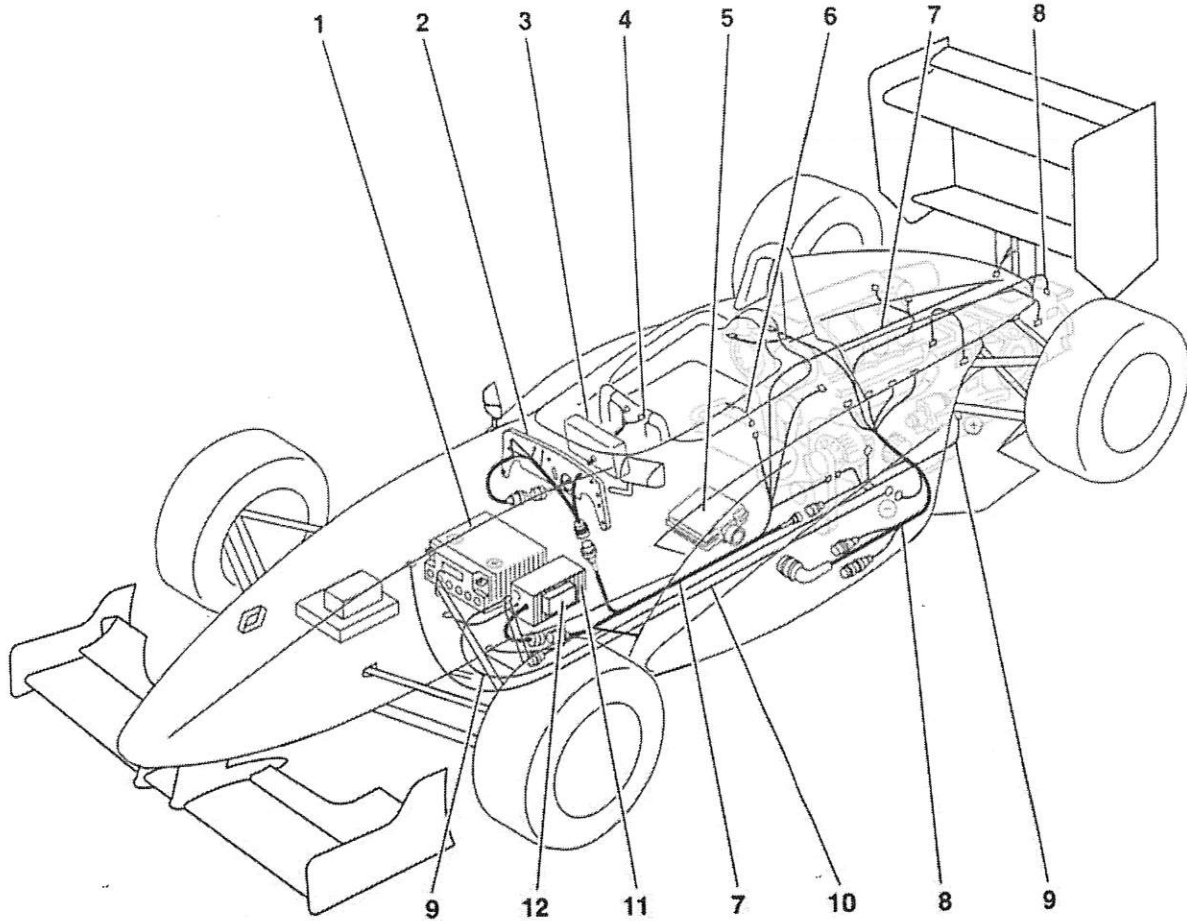

ITEM N°	DESCRIPTION	ITEM N°	DESCRIPTION
1	Battery	7	Frame wiring
2	Dashboard wiring	8	Engine wiring
3	Dashboard	9	Starter wiring
4	Steering wheel wiring	10	Battery earth wiring
5	Computer	11	Battery main switch
6	Extinguisher wiring	12	Gearbox

## FRAME HARNESS

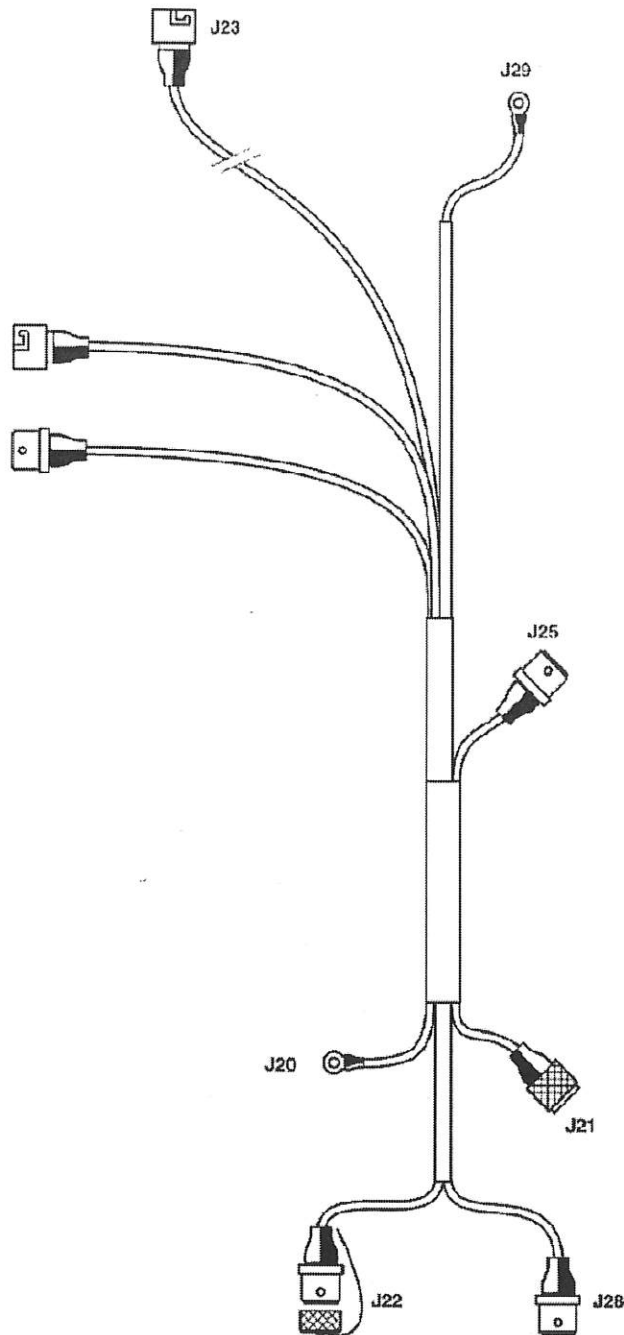

ITEM N°	DESCRIPTION	ITEM N°	DESCRIPTION
J20	Battery earth	J26	Auxiliary
J21	Battery main switch	J27	Extinguisher
J22	Speed connector	J28	Dashboard
J23	Rain light	J29	Starter excitation
J25	Engine harness connection		

## ENGINE HARNESS

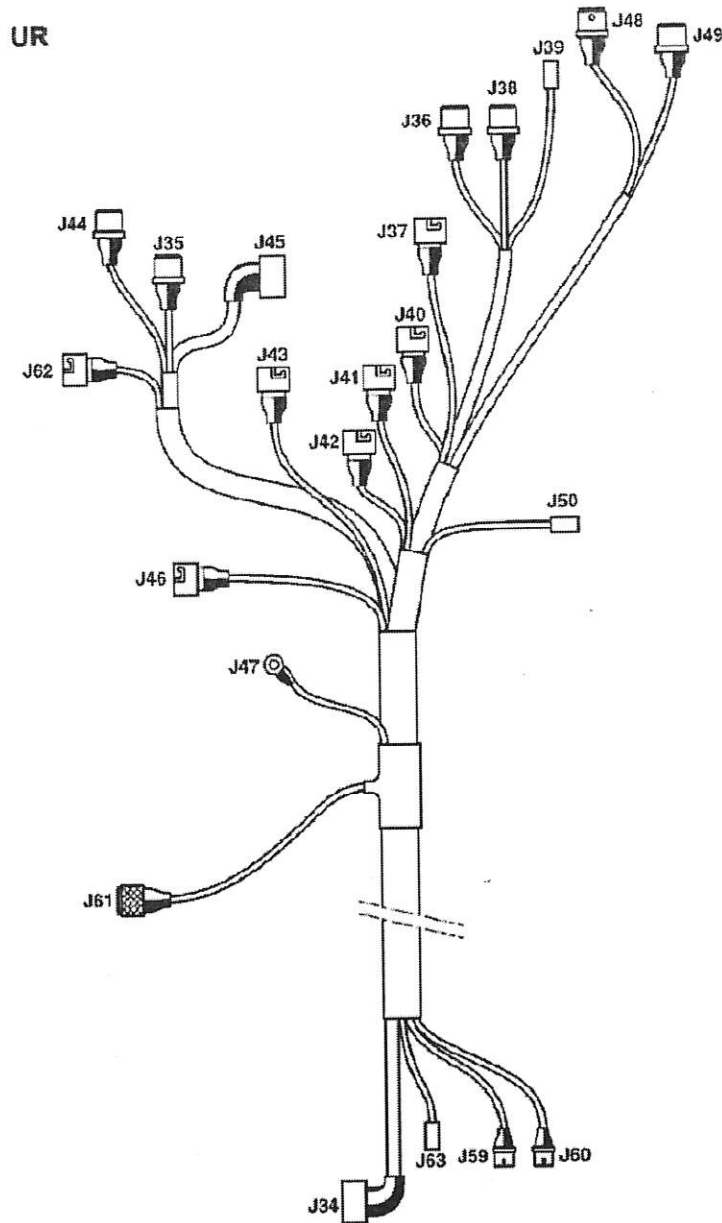

ITEM N°	DESCRIPTION	ITEM N°	DESCRIPTION
J34	Computer	J45	Coil
J35	Air pressure	J46	TDC
J36	Butterfly valve	J47	Engine earth
J37	Air temperature	J48	Gearbox potentiometer
J38	Water temperature	J49	Gearbox contactor
J39	Oxygen probe	J50	Oil pressure
J40	Injector 1	J59	Diagnostic
J41	Injector 2	J60	Acquisition
J42	Injector 3	J61	frame connection
J43	Injector 4	J62	Pump
J44	Camshaft offset	J63	Oil pressure interface

DASHBOARD HARNESS

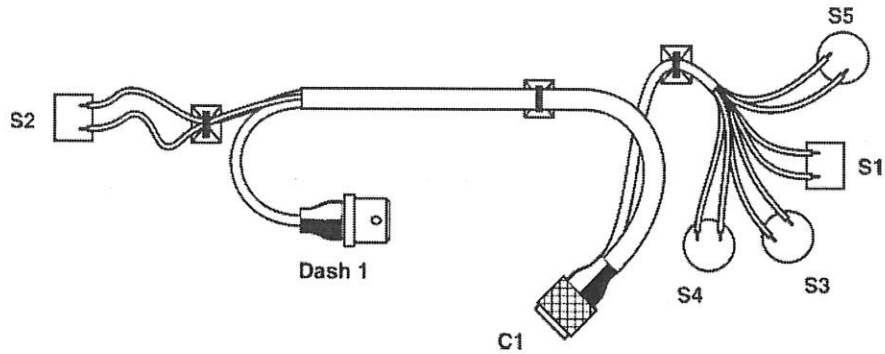

ITEM N°	DESCRIPTION	ITEM N°	DESCRIPTION
C1	Frame harness	S3	START starter pushbutton
Dash 1	Air Dashboard	S4	Battery ON pushbutton
S1	Ignition switch	S5	Battery OFF pushbutton
S2	Rain light on/off switch		

### FRAME WIRING DIAGRAMM

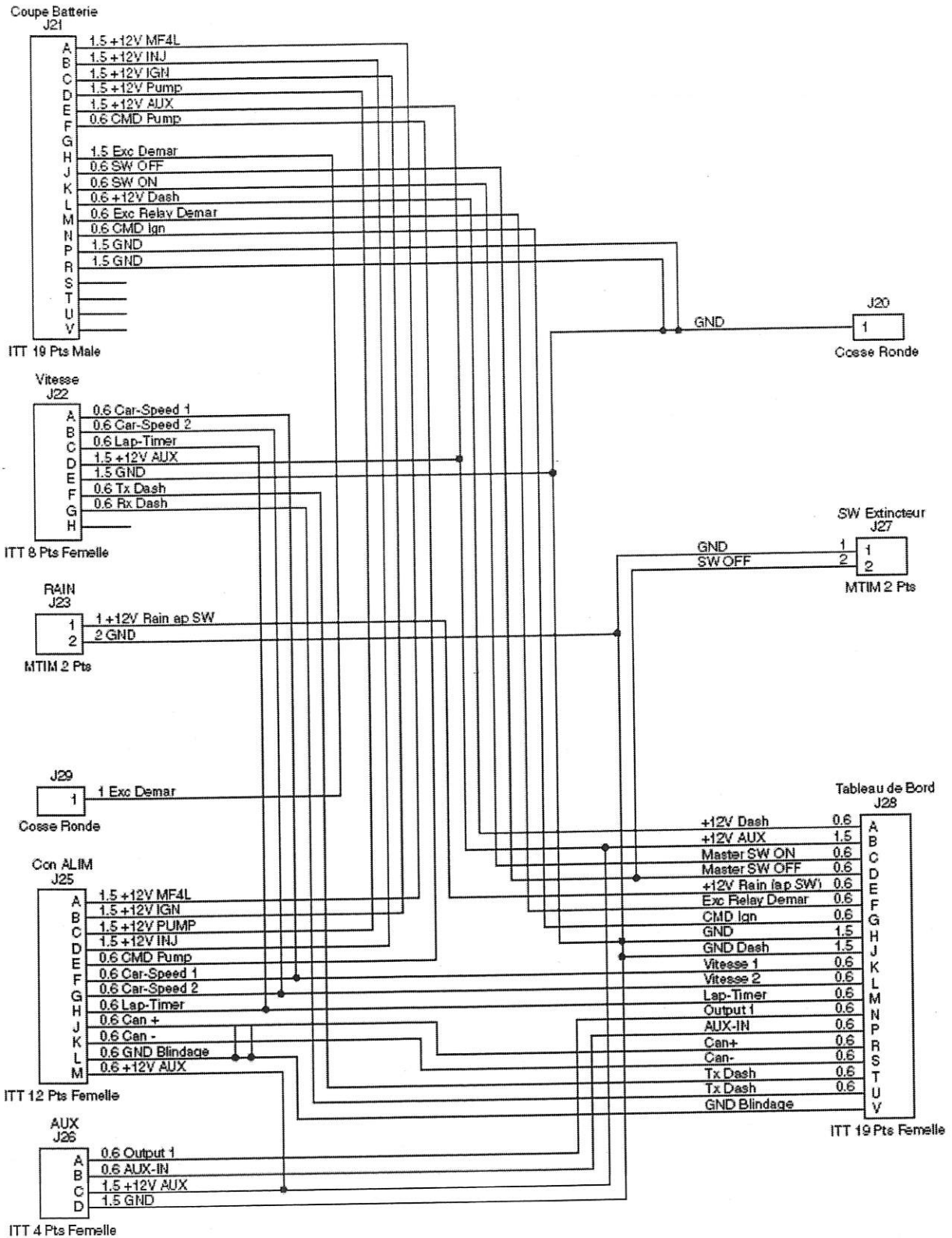

ENGINE WIRING DIAGRAM

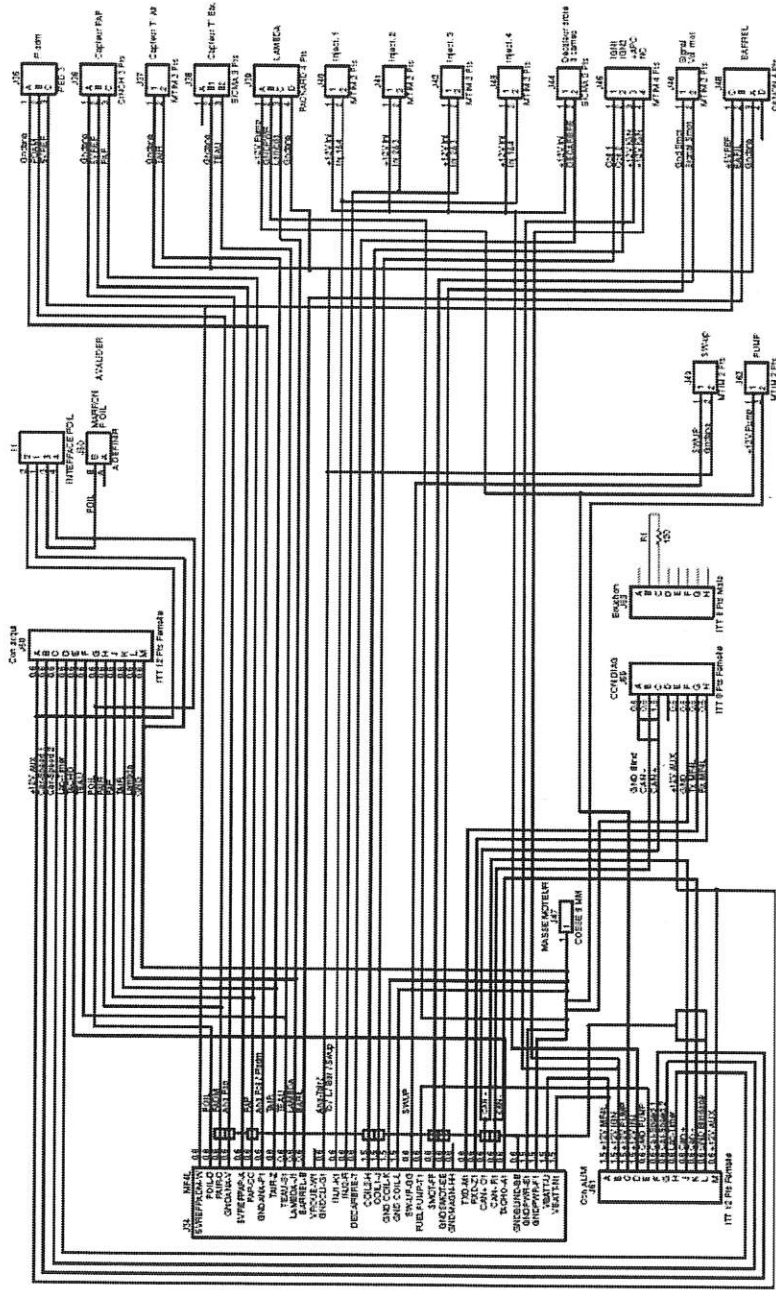

### DASHBOARD WIRING DIAGRAMM

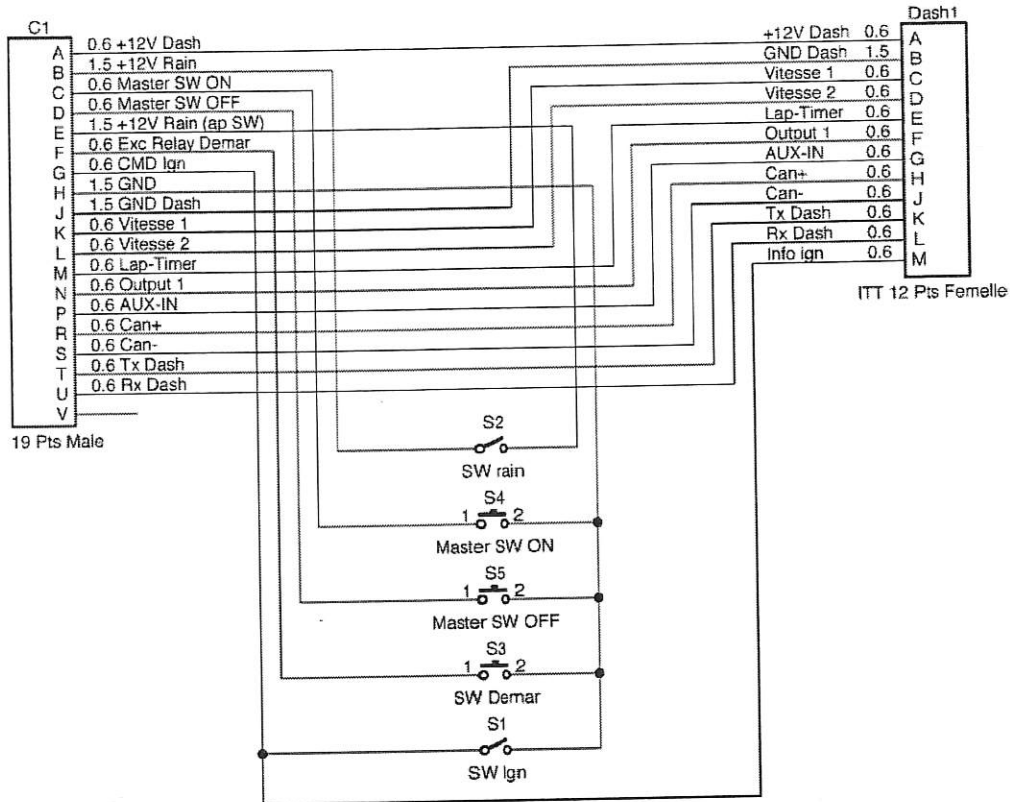



**FRAME HARNESS CONNECTORS**

**Battery Ground J20**

PIN	SIGNAL	TO	
		PIN	CONNECTOR
Pin $\Phi$ 6	Battery Ground	H and J	J28
		E	J22
		P and R	J21
		2	J23
		D	J26

**Fuse box J21**

PIN	SIGNAL	TO	
		PIN	CONNECTOR
A	+12V MF4L	A	J25
B	+12V INJ	D	J25
C	+12V IGN	B	J25
D	+12V fuel pump	C	J25
E	+12V auxiliary	D	J25
		M	J26
		C	J28
		B	J22
F	Fuel pump command	E	J25
H	Starter excitation		J29
J	Master switch "OFF"	2	J27
K	Master switch "ON"	D	J28
L	+12V Dashboard	C	J28
M	Relay of starter excitation	A	J28
N	Commande ignition	F	J28
P	Ground battery	G	J28
R	Ground battery		J20
			J20

**Speed connector J22**

PIN	SIGNAL	TO	
		PIN	CONNECTOR
A	Speed 1	F	J25
		K	J28
B	Speed 2	G	J25
		L	J28
C	Lap timer	H	J25
		M	J28
D	+12V auxiliary	M	J25
		C	J26
		E	J21
		B	J28
E	Ground battery		J20
F	Tx Dashboard	T	J28
G	Rx Dashboard	U	J28

**Rain light J23**

PIN	SIGNAL	TO	
		PIN	CONNECTOR
1	+12V Rain light Switch	E	J28
2	Ground battery		J20

**Engine connector J25**

PIN	SIGNAL	TO	
		PIN	CONNECTOR
A	+12V APC ECU	A	J21
B	+12V Coil	C	J21
C	+12V fuel pump	D	J21
D	+12V injectors	B	J21
E	Fuel pump command	F	J21
F	Speed 1	A	J22
		K	J28
G	Speed 2	B	J22
		L	J28
H	Lap timer	C	J22
		M	J28
J	CAN line +	R	J28
K	CAN line -	S	J28
L	Ground	V	J28
		C	J26
M	+12V auxiliary	E	J21
		B	J28
		D	J22

**Auxiliary alimentation J26**

PIN	SIGNAL	TO	
		PIN	CONNECTOR
A	Output 1	N	J28
B	Output 2	P	J28
C	+12V auxiliary	M	J25
		E	J21
		B	J28
		D	J22
D	Ground battery		J20

**Extinctor command J27**

PIN	SIGNAL	TO	
		PIN	CONNECTOR
1	Ground battery		J20
2	Master switch "OFF"	D	J28
		J	J21

## Dashboard J28

PIN	SIGNAL	TO	
		PIN	CONNECTOR
A	+12V Dashboard	L	J21
B	+12V auxiliary	M	J25
		C	J26
		E	J21
		D	J22
C	Masterswitch "ON"	K	J21
D	Masterswitch "OFF"	2	J27
E	Rain light switch	J	J21
		1	J23
F	Starter relay excitation	M	J21
G	Ignition switch	N	J21
H	Ground battery		J20
J	Ground battery		J20
K	Speed 1	F	J25
		A	J22
L	Speed 2	G	J25
		B	J22
M	Lap timer	H	J25
		C	J22
N	Output 1	A	J26
P	Output 2	B	J26
R	Line CAN +	J	J25
S	Line CAN -	K	J25
T	Txd Dashboard	F	J22
U	Rxd Dashboard	G	J22
V	Shoring	L	J25

## Starter J29

PIN	SIGNAL	TO	
		PIN	CONNECTOR
Clip	Starter excitation	H	J21

**ENGINE HARNESS CONNECTORS**

**ECU C10**

PIN	SIGNAL	TO	
		PIN	CONNECTOR
A	Reference voltage 5V	B	J36
B	Gearbox barrel signal	C	J48
C	Air pressure signal	B	J35
		H	J60
D	Oil pressure signal	4	J63
		G	J60
H	Coil cylinders 2 and 3	2	J45
J	Coil cylinders 1 and 4	1	J45
K	Ignition power ground		J47
L	Ignition power ground		J47
		2	J42
R	Injectors 2 and 3	1	J41
T	Crankshaft shifter command	2	J44
U	+12V incoming and battery	N1	J34
		A	J61
V	Analogic ground	A	J36
		C	J35
W	Reference voltage 5V	B	J48
		K	J60
Z	Air temperature signal	2	J37
A1	Revs	E	J60
E1	Power ground		J47
F1	Power ground		J47
		B1	J38
		1	J37
G1	Nock ground	D	J39
		A	J48
		2	J49
		L	J60
J1	Oxygen probe signal	C	J39
		2	J43
K1	Injectors 1 and 4	2	J40
		G	J59
M1	Txd (Line display)		
N1	+12V incoming and battery	N1	J34
		A	J61
P1	Analogic ground	A	J35
		C	J59
Q1	CAN line +	J	J61
		B	J59
R1	CAN line -	K	J61
		F	J60
S1	Water temperature	B2	J38
		E	J61
T1	Fuel pump command		
Z	Rxd (line display)	H	J59
BB	Shoring ground	L	J61
		C	J36
CC	Throttle potentiometer	J	J60
EE	PMH signal -	1	J46
FF	PMH signal +	2	J46
GG	Gearbox contactor	1	J49

**Air pressure sensor J35**

PIN	SIGNAL	TO	
		PIN	CONNECTOR
A	Analogic ground	P1	J34
B	Air pressure signal	C	J34
C	Reference voltage +5V	W	J34

**Throttle potentiometer J36**

PIN	SIGNAL	TO	
		PIN	CONNECTOR
A	Analogic ground	V	J34
B	Reference ground + 5V	A	J34
C	Potentiometer signal	CC	J34

**Air temperature sensor J37**

PIN	SIGNAL	TO	
		PIN	CONNECTOR
1	Nock ground	G1	J34
		B1	J38
		D	J39
		A	J48
		2	J49
2	Water temperature	Z	J34
		K	J60

**Water temperature sensor J38**

PIN	SIGNAL	TO	
		PIN	CONNECTOR
B1	Nock ground	G1	J34
		1	J37
		D	J39
		A	J48
		2	J49
B2	Water temperature	S1	J34
		F	J60

**Lambda sensor J39**

PIN	SIGNAL	TO	
		PIN	CONNECTOR
A	+12V AVC Fuel pump	C	J61
		1	J62
			J47
B	Engine ground		
C	Oxygen probe	J1	J34
		L	J60
D	Analogic ground	G1	J34
		B1	J38
		1	J37
		A	J48
		2	J49

**Injector 1 J40**

PIN	SIGNAL	TO	
		PIN	CONNECTOR
1	+12V APC ignition injector	D	J61
		1	J41
		1	J42
		1	J43
		1	J44
2	Output injector 1 and 4	K1	J34
		2	J43

**Injector 2 J41**

PIN	SIGNAL	TO	
		PIN	CONNECTOR
1	+12V APC ignition injector	D	J61
		1	J40
		1	J42
		1	J43
		1	J44
2	Output injector 2 and 3	R	J34
		1	J42

**Injector 3 J42**

PIN	SIGNAL	TO	
		PIN	CONNECTOR
1	+12V APC ignition injector	D	J61
		1	J40
		1	J41
		1	J43
		1	J44
2	Output injector 2 and 3	R	J34
		1	J41

### Injector 4 J43

PIN	SIGNAL	TO	
		PIN	CONNECTOR
1	+12V APC ignition injector	D	J61
		1	J42
		1	J41
		1	J40
		1	J44
2	Output injector 2 and 4	K1	J34
		2	J40

### Camshaft shifter J44

PIN	SIGNAL	TO	
		PIN	CONNECTOR
1	+12V APC	D	J61
		1	J40
		1	J41
		1	J42
		1	J43
2	Camshaft shifter command	T	J34

### Coil J45

PIN	SIGNAL	TO	
		PIN	CONNECTOR
1	Cylinder coil command 1 and 4	J	J34
2	Cylinder coil command 2 and 3	H	J34
3	+12V Coil	B	J61
		4	J45
4	+12V Coil	B	J61
		3	J45

### Capteur PMH J46

PIN	SIGNAL	TO	
		PIN	CONNECTOR
1	Ground	EE	J34
2	Entrée capteur volant moteur	FF	J34

### Barrel potentiometer J48

PIN	SIGNAL	TO	
		PIN	CONNECTOR
A	Nock ground	G1	J34
		B1	J38
		1	J37
		D	J39
		2	J49
B	Reference voltage +5V	W	J34
C	Barrel gearbox	B	J34

**Gearbox J49**

PIN	SIGNAL	TO	
		PIN	CONNECTOR
1	Signal	GG	J34
2	Ground	G1	J34
		B1	J38
		1	J37
		D	J39
		A	J48

**Oil pressure sensor J50**

PIN	SIGNAL	TO	
		PIN	CONNECTOR
B	Oil pressure	3	J63

**Diagnostic J 59**

PIN	SIGNAL	TO	
		PIN	CONNECTOR
A	Shoring ground		
B	CAN line -	R1	J34
C	CAN line +	Q1	J34
E	+12V auxiliary	2	J63
		M	J61
		A	J60
			J63
F	Engine ground	1	J62
		2	J60
		M	J39
		B	J47
			J34
G	Txd ECU	M1	J34
H	Rxd ECU	Z1	J34



## Acquisition J60

PIN	SIGNAL	TO	
		PIN	CONNECTOR
A	+12V auxiliary	M	J61
		E	J59
B	Speed 1	F	J61
C	Speed 2	G	J61
D	Signal lap timer	H	J61
E	Tachymetre	A1	J34
F	Water temperature	S1	J34
		B2	J38
G	Oil pressure	D	J34
		4	J63
H	Air pressure	C	J34
J	Throttle potentiometer	CC	J34
K	Air temperature	Z	J34
		2	J37
L	Oxygen probe	J1	J34
		C	J39
M	Engine probe	F	J59
		2	J62
		B	J39
		B	J47

## Frame connector J61

PIN	SIGNAL	TO	
		PIN	CONNECTOR
A	+12V APC ECU	U and N1	J34
B	+12V Coil	3 and 4	J45
C	+12V Fuel pump	A	J39
		1	J62
D	+12V injectors	1	J40
		1	J41
		1	J42
		1	J43
		1	J44
E	Fuel pump command	T1	J34
F	Speed 1	B	J60
G	Speed 2	C	J60
H	Lap timer	D	J60
J	CAN line+	Q1	J34
K	CAN line -	R1	J34
L	Shoring ground	BB	J34
M	+12V auxiliary	A	J60
		E	J59

**Fuel pump J62**

PIN	SIGNAL	TO	
		PIN	CONNECTOR
1	+12V APC ignition injectors	D	J61
		1	J41
		1	J42
		1	J43
		1	J44
2	Engine ground		J59
		F	J60
		M	J39
		B	J47

**Oil pressure electronic plate J63**

PIN	SIGNAL	TO	
		PIN	CONNECTOR
1	Engine ground	F	J59
			J47
2	+12V auxiliary	E	J59
3	Input signal	B	J59
4	Output ECU	D	J34
		G	J60

**Cap J64**

PIN	SIGNAL	TO	
		PIN	CONNECTOR
B	CAN line -		Résistance 120Ω
C	CAN line +		Résistance 120Ω

## STARTUP

The logos opposite appear for 2s when switching on:

**NOTA:** If the IGN switch is in the ON position, the logos do not appear so as not to lose time when a power disturbance reboots the dashboard while the car is running. Press one of the steering wheel pushbuttons to interrupt display of the logos.

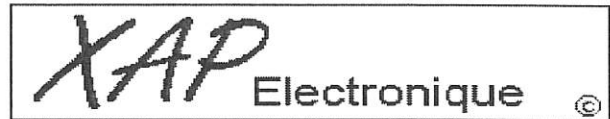

## SETUP SCREENS

The setup screens can be accessed by simultaneously pressing the two pushbuttons when the Renault Sport FR 2.0 and XAP logos are displayed.

Choose the screens you want in the scrolling menu:

- SW1 to choose the driver's screen which can be accessed using the right pushbutton on the steering wheel.
- SW2 to choose the driver's screen which can be accessed using the left pushbutton on the steering wheel.
- LEDS to configure the 12 red speed LEDs.
- LAP to change the parameters for the lap and speed option.

Push the right pushbutton to scroll the cursor and the left pushbutton to enable your choice.

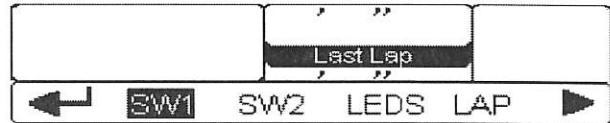

## SCREENS SW1 AND SW 2

With the IGN switch set to "ON", the driver can only access the two screens selected with the right or left pushbuttons. These screens are selected by going into dashboard setup mode using options SW1 and SW2.

- Push the right pushbutton to select the screen you want.
- Enable by pressing the left pushbutton.



## LEDS SETUP

For each LED, these screens configure the speed at which it lights up rpm ON, and at which it goes off, rpm OFF.

Therpm OFF and rpm ON values are changed by adjusting the position of the engine throttle with the left pushbutton pressed down.

When the value you want is displayed, release the left pushbutton to enable it.



The right pushbutton is used to go to another variable to be configured or to another LED.



The LED for therpm ON and rpm OFF value adjustment lights up.

When all therpm OFF and rpm ON values have been set, the screen opposite appears so that you can check that the LEDs are properly set.

The displayed speed varies as a function of the accelerator position, and lights them up as a function of the configuration selected.

- Use the right pushbutton to exit.

RPM ON : 5600    RPM OFF : 5600		
 Modify	Adjust with throttle	Next 

6750		
 Valid	Adjust with throttle	Next 

## LAP AND SPEED SETUP

The lap and speed setup screen can be accessed using the lap and speed option. This screen is used to configure the following parameters:

- Display time for lap time screen: normally 4s.
- Display delay for lap time screen: normally 0s.
- Min. time for best lap (min. lap time).
- Diameter of wheel for speed measurement (wheel dia.): normally 1700mm.
- Number of contacts per wheel (pulse/rev.): 4 if DPS/ AIM target.
- Display in Kph or Mph (metric or imperial).



Use the right pushbutton to move the cursor and the left one to enable your selection. This value is underlined when its can be changed.

Change values by adjusting the engine throttle position, with the left pushbutton pressed down (method similar to LED setup).

When the value you want is displayed, release the left inter to enable it.

To go to another variable for configuration, use the right pushbutton.

When all the variables are enabled, put the cursor on "Quit" (exit) and press right pushbutton to enable.

Display time :	s	W.Perimeter :	mm
Display delay :	s	Metric :	Imperial
Min Lap Time :	s	Quit :	Return
 Valid	Adjust with throttle	Next 	

### RACE, DIAG., DATALOG AND LAP MODES

- With the IGN switch set to "OFF", press the right pushbutton. The Diag, Race, DataLog and Lap menu appears.
- Select the mode you want using the left pushbutton.
- Press right button again to enable.

You can access the screens for each of these modes by pressing the left pushbutton.

With the IGN switch set to "ON", the driver can only access the two screens selected with the right and left pushbuttons. These screens are selected by going into dashboard setup mode using options SW1 and SW2. This screen selection prevents the driver from getting lost in the numerous screens that are available.

### RACE SCREENS

The race screens display, at all times, information indispensable to the driver (speed and gear).

Depending on the screen, other information is also displayed: oil pressure, battery voltage, water temperature, and lap time.

The lap and speed option has:

- the two screens shown opposite

- This screen, which the driver uses to get his or her lap time and also to monitor engine parameters.

This appears x seconds after passing in front of the infrared emitter beacon for a duration of y seconds. Parameters x and y can be adjusted using the lap time setup menu. This flexibility allows the driver to easily and safely read his or her time even if the beacon is placed just before a critical curve.

In addition, when the driver does his or her best time, the screen flashes in 2Hz reverse mode.

**NOTA:** This screen can be deactivated by selecting a zero display time on the "setup" screen.

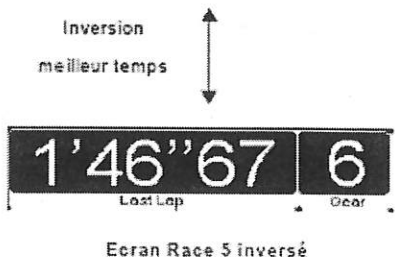
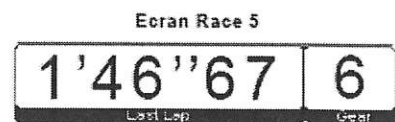
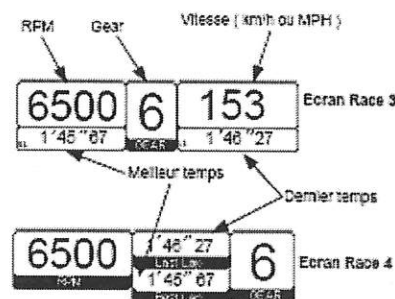
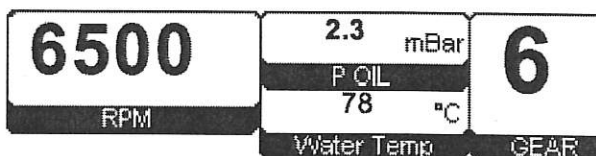

## DIAG 1, 2 AND 3 SCREENS

The Diag screens display the level of the engine sensors, as well as troubleshooting information.

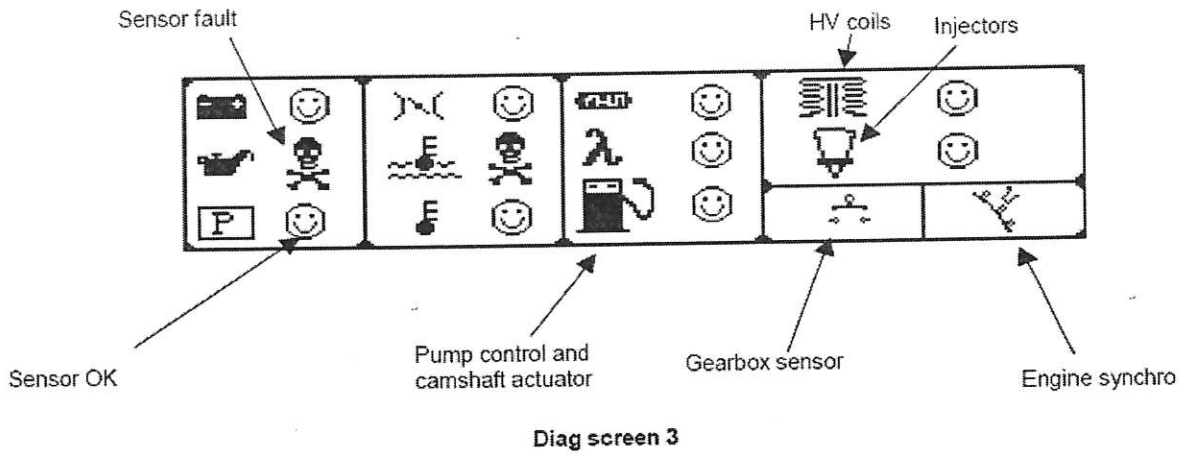
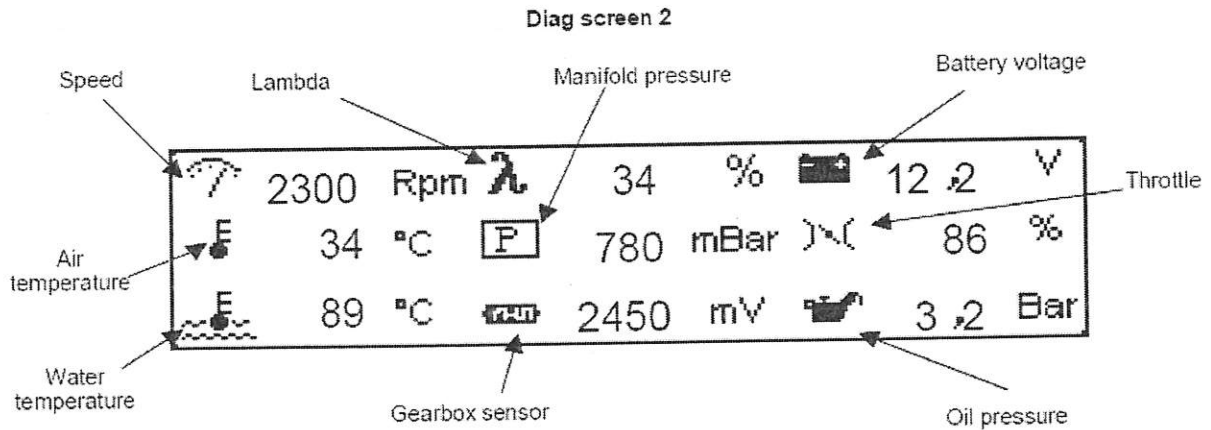

### DATALOG SCREEN

The dashboard continually records the parameters listed below in memory:

- Max. Speed.
- Max. Speed in 6<sup>th</sup> gear.
- Oil pressure, min. and max. Values.
- Water temperature, min. and max. Values.
- Air temperature, min. and max. Values.
- Battery voltage, min. and max. Values.
- Consumption.
- Storage in memory of number of sensor faults and alerts.

RPM Max	8 750	Trs/min
RPM Max Gear 6	6 750	Trs/min
P oil Min-Max	1.2 - 6.7	Bar
Water T° Min-Max	7.8 - 8.9	°C

Ecran DataLog 1

Recording starts when the engine speed exceeds 2000rpm and stops when it drops to below 500rpm. Data are reinitialised as soon as the engine speed goes back up to 2000rpm.

DataLog screen2

Air T° Min-Max	24 - 32	°C
V Bat Min-Max	12.7 - 13.5	V
Consommation	12.7	Litres
Capteurs Alerte-Défaut	0 1 0 - 12	Nbr

Number of sensor faults

Oil pressure alert
Water temperature alert
Battery voltage alert

**0** : no alert
**1** : at least 1 alert

DataLog screen 3

0	0	0	0
0	0	0	0
1	1	0	0 0

**0** : no sensor faults
**1** : at least 1 sensor fault

This screen is available using the lap and speed option.

Ecran DataLog 4

Max Speed	2 2 3
Number of Lap	2 3
Best Lap	1' 46" 67
Overage Lap-Time	1' 46" 95



## LAP SCREEN

This mode gives you the time for all laps in memory, on a single screen.

This mode can only be accessed using the lap and speed option.

The last eight laps are always displayed on the screen, and change as a function of the number of laps.

Nonetheless, you can go back to the laps that are no longer displayed on the screen by pressing the left pushbutton.

The lap times are reset when the master ON/OFF switch is set to OFF and when the engine goes back up to 2000rpm.

## CONTRAST ADJUSTMENT

The contrast can be adjusted at any time.

- Press both pushbuttons at the same time.
- When the contrast screen appears:
  - decrease using the left pushbutton,
  - Increase using the right pushbutton.
- Press both pushbuttons at the same time to exit.

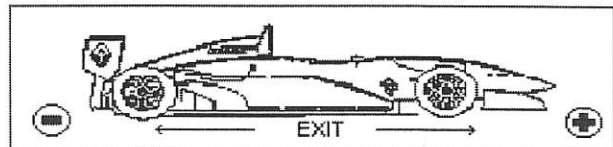

## ALERT MODE

The dashboard goes into alert mode when one of the following conditions appears:

- Oil pressure < 2bar or > 6bar if rpm > 2000rpm.
- Water temperature > 110°C if rpm > 1000rpm.
- Battery voltage < 11V if rpm > 400rpm.

The screen flashes in reverse mode on sensor screen 1.

Press right pushbutton to acknowledge alert and return to the previous screen.

As long as the alert is active, the first LED will flash rapidly.

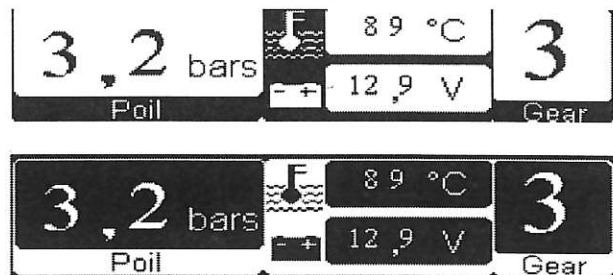

## DATA ACQUISITION AND PERFORMANCE ANALYZER OPTION

The data acquisition and performance analyser option allows the driver and the tuning person to display recorded data on the dashboard, and to compare two laps to each other. This can be done during a test session, when data acquisition is not being used in order not to lose time.

The main characteristics of this option are:

- Real-time performance analysis mode.
- Comparison mode for two laps accessible on dashboard.
- Integration of data acquisition.

### On track: real-time performance analysis mode

This screen can be selected instead of the race 2 screen.

It shows the advance or lag for the lap in real time, in relation to a perfect, theoretical lap.

The screen displays:

- Speed.
- Gear.
- Timer, which starts as soon as the dashboard is switched on, and which shows the time elapsed since the beginning of the session (< 59min 59s). It is reset when the master ON/OFF switch is activated.
- Display of advance or lag in real time and in large characters, in hundredths of seconds (in this case, the driver is 0,42s ahead).
- The bargraph, which shows the advance or lag, with one square corresponding to a tenth of a second. If the bargraph goes to the right, this signals that the current lap is ahead in relation to the reference.

**NOTA:** For the performance analyser to function correctly, it is indispensable to initialise the dashboard memory. The performance analyser is therefore not operational during the first laps on a new circuit.



### In stands: mode for comparing two laps accessible

In the lap menu, the first screen is used to select a reference lap.

The cursor is automatically points towards the best lap for the session. Move with the right pushbutton and select a lap using the left pushbutton.

Once the reference lap has been selected, the strip asking for the lap to be compared is displayed on the screen.

Movement is still with the right pushbutton and enabling with the left pushbutton.

When both laps have been selected, "comptime" (comparison time) appears on the screen.

The graph unit is: 1 pixel = 0,02s. The display accepts a range of +/-0,4s. When the graph moves upwards, the driver is lagging behind; when it moves downwards the driver is ahead, as shown by the number at the top right.

For reasons of quickness, the cursor moves 8 pixels by 8 pixels.

If the driver moves the cursor on the screen using the right pushbutton and validates using the left pushbutton, he or she can select where they want to examine the acquisition data. There will then be a switch to the analysis screen, next section.

### Data Acquisition

The recording shown always points to a fiftieth of a meter before the selected range.

By moving forwards or backwards respectively, the driver and the tuning person can find out why the driver has gained 32s on the 1754m distance of the circuit.

Example: comparison of reference lap in 1'32'45 with the lap in 1'32'28. In the 1754m position on the circuit, it is possible to see that:

- On the reference lap, the driver is at 6950rpm, at 184kph, in 6<sup>th</sup> gear, and at 99% throttle.
- On the compared lap, the driver is at 6850rpm, at 180kph, in 6<sup>th</sup> gear, and at 99% throttle. He or she is ahead by 0,32s in relation to the reference lap.

The bar graph repeats this advance in tenths, as on the real time screen. A smiley is displayed next to the lap in advance and the skull next to the lag.

Press the pushbuttons twice simultaneously during display of the last screen to exit from analysis mode

1	1' 32" 11	2	1' 32" 67
3	1' 32" 45	4	1' 32" 28
5	1' 32" 34	6	1' 32" 23
Valid		REFERENCE LAP	Next

1	1' 32" 11	2	1' 32" 67
3	1' 32" 45	4	1' 32" 28
5	1' 32" 34	6	1' 32" 23
Valid		COMP LAP	Next

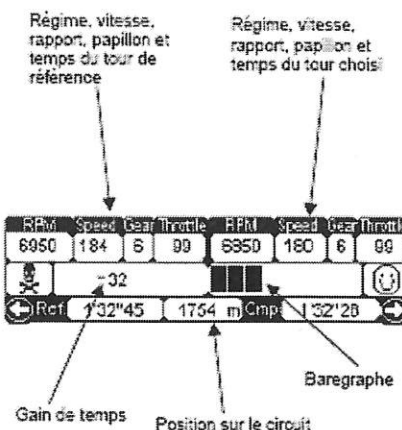
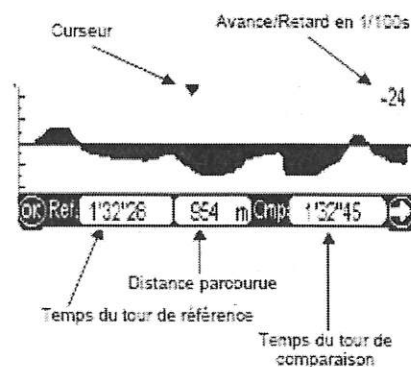

## BATTERY CHARGE

The battery charge is max. 5A/h.

**IMPORTANT:** Disconnect battery cables (2) before charging battery. Failure to follow these instructions leads to destruction of the alternator voltage regulator.

## RESERVE BATTERY

When using a reserve battery, connect it directly to the terminals of the main battery with an explosion-proof connector.

**IMPORTANT:** In order that the operator stays behind the vehicle to do the connection, this one must necessary be placed behind the rear axle assembly.

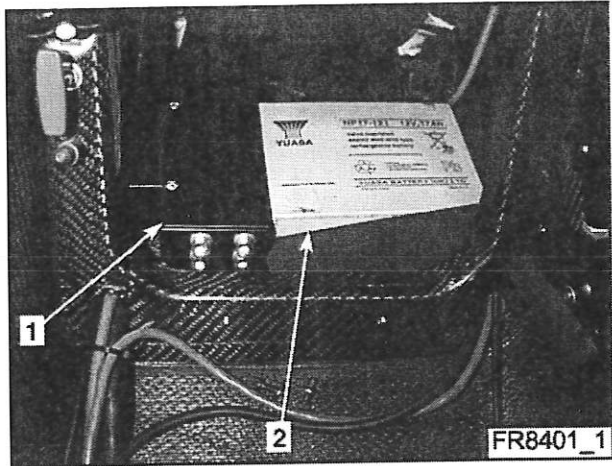

## FUSEBOX

### Functioning

If startup is not being controlled 20min after switching on the electrical circuit, the fuse (1) automatically cuts off the electricity supply.

### Connector

A	+12V MF4L	Light-Green	Fuse 10A (3) MF4L Dashboard
B	+12V INJ	Dark-green	Fuse 20A (2) Coil and injectors
C	+12V IGN	Grey	Fuse 20A (2) Coil and injectors
D	+12V fuel pump	Black	
E	+12V auxiliary	Pink	Fuse 10A (4) auxiliary
F	Fuel pump command	Black/Green	
G	Alternator excitation	Red	Fuse 20A (1) Pump and Starter
H	Starter excitation	Blue	
J	SW OFF	Light-Pink	
K	SW ON	Brown	
L	+12V Dashboard	Light-Green	Fuse 10A (3) MF4L and dashboard
M	Starter relay excitation	Red	
N	IGN Command	Light Blue	
P	Ground	Orange	
R	Ground	Yellow	

**NOTA:** Wait 20s before closing back a thermal fuse that has tripped.

